

# Small hydropower technologies - European state-of-the-art innovations





## ABOUT HYPOSO

HYPOSO ([www.hyposo.eu](http://www.hyposo.eu)) is a multi-approach project to tackle several objectives; identification and mapping of the European hydropower industry, hydropower stakeholders in the HYPOSO target countries, education of new hydropower experts through capacity building activities and bringing together relevant actors from the EU hydropower sector with stakeholders in the target countries. Interaction with stakeholders is therefore an integral part of the activities, as workshops, capacity building activities and interviews with national/local stakeholders are envisaged in all target countries which are outside the European Union, namely workshops in Bolivia, Colombia and Ecuador in Latin America, and in Cameroon and Uganda in Africa. Additionally, capacity building courses will be carried out in Bolivia and Ecuador, and in Cameroon and Uganda.

## ABOUT THIS DOCUMENT

Editors:	Ingo Ball, Dirk Hendricks, Tasniem Siegfried Jawaïd, Dominik Rutz, Janusz Steller
Authors:	Ingo Ball, Lea Berg, Marc J. Buiting, Dominique Courret, Laurent David, Vincent Denis, Manon Dewitte, Adam Henke, Waldemar Janicki, Tasniem Siegfried Jawaïd, Cécile Münch-Alligné, Luigi Lorenzo Papetti, Bernhard Pelikan, Sylvain Richard, Peter Rutschmann, Pierre Sagnes, Janusz Steller
ISBN:	978-3-936338-75-1
Translations:	The original language of the handbook is English. This handbook is also available in French and in Spanish
Published:	© 2020 by WIP Renewable Energies, Munich, Germany
Edition:	1 <sup>st</sup> edition
Contact:	WIP Renewable Energies, Sylvensteinstr. 2, 81369 Munich, Germany <a href="mailto:Ingo.Ball@wip-munich.de">Ingo.Ball@wip-munich.de</a> , Tel.: +49 89 720 12 718 <a href="http://www.wip-munich.de">www.wip-munich.de</a>
Website:	<a href="https://www.hyposo.eu/">https://www.hyposo.eu/</a>
Copyright:	All rights reserved. No part of this book may be reproduced in any form or by any means, in order to be used for commercial purposes, without permission in writing from the publisher. The authors do not guarantee the correctness and/or the completeness of the information and the data included or described in this handbook.
Cover page:	Image provided by Studio Frosio

## ACKNOWLEDGEMENT & DISCLAIMER



This project has received funding from the European Union's Horizon 2020 research and innovation programme under grant agreement No 857851. Neither the European Commission nor any person acting on behalf of the Commission is responsible for how the following information is used. The views expressed in this handbook are the sole responsibility of the authors and do not necessarily reflect the views of the European Commission.

Reproduction and translation for non-commercial purposes are authorised, provided the source is acknowledged and the publisher is given prior notice and sent a copy.

## PROJECT CONSORTIUM AND NATIONAL CONTACT POINTS:



**WIP Renewable Energies**, project coordinator, Germany  
Ingo Ball [ingo.ball@wip-munich.de]  
www.wip-munich.de



**1<sup>to</sup>3 Capital B.V.**, The Netherlands  
Marc J.M. Buiting [buiting@1to3capital.com]  
www.1to3capital.eu



**CELAPEH**, Colombia  
Carlos Velasquez [direccion@celapeh.org]  
www.celapeh.org



**Escuela Politécnica Nacional**, Ecuador  
Verónica Minaya [veronica.minaya@epn.edu.ec]  
www.epn.edu.ec/



**European Renewable Energies Federation**, Belgium  
Dirk Hendricks [dirk.hendricks@eref-europe.org]  
www.eref-europe.org



**Hydropower Association of Uganda Ltd. (HPAU)**, Uganda  
Dan Marlone Nabutsabi [dmarlone@yahoo.com]  
www.hpau.org



**IHE Delft Institute for Water Education**, The Netherlands  
Miroslav Marenc [m.marenc@un-ihe.org]  
www.un-ihe.org/



**Institute of Fluid-Flow Machinery, Pol.Ac.Sci.**, Poland  
Janusz Steller [steller@imp.gda.pl]  
www.imp.gda.pl



**SOLARHYDROWATT**, Cameroon  
Joseph Kenfack [joskenfack@yahoo.fr]  
www.solarhydrowatt.com



**STUDIO FROSIO S.r.l.**, Italy  
Luigi Lorenzo Papetti [luigi.papetti@studiofrosio.it]  
www.studiofrosio.it/en/



**TRMEW sp. z o.o.**, Poland  
Ewa Malicka [ewa.malicka@trmew.pl]  
www.trmew.pl



**Universidad Mayor de San Simón**, Bolivia  
Andres Gonzales Amaya [andresgonzales.a@fcyt.umss.edu.bo]  
www.umss.edu.bo



**Vytautas Magnus University**, Lithuania  
Petras Punys [petras.punys@vdu.lt]  
www.vdu.lt/en/

## Foreword

Dear reader,

the handbook you have in front of you is a product of the "HYPOSO" project and at the same time a true product of European expertise and collegial cooperation.

In addition to information on the history and on the application areas of small hydropower, this handbook shows and describes various technical solutions for the small hydropower sector. Valuable information on planning and financing models complete this book.

Many thanks to all contributors of the handbook. The content was developed and written by renowned experts from the HYPOSO consortium. In order to describe the latest developments in the small hydropower sector, which also serve to exploit unused potentials and to increase fish-friendliness, contact was made with various EU initiatives and ongoing projects. Thanks go to the Horizon 2020 project "Hydropower Europe" for facilitating the contact with the expert Prof. Cécile Münch-Aligné, who also represents the Horizon 2020 project "XFLEX Hydro". Valuable input on fish-friendly concepts came from the Horizon 2020 project "FIThydro", represented by Lea Berg and Prof. Peter Rutschmann. Information on the latest opportunities in hidden hydro as well as turbine technology was supported by Vincent Denis, who is associated with EU projects as an evaluator. Below you will find some more information on the authors external to the project.

In the hope that you will enjoy reading this handbook, I also hope that this book will help to deepen interest in small hydropower and provide a small support for the sector.

Munich, December 2020

Ingo Ball  
WIP Renewable Energies  
(HYPOSO Project Coordinator)

## The guest authors



**Prof. Cécile Münch-Alligné**

Organisation : Hydroelectricity research group, HES SO Valais-Wallis

Edited chapter : 3.1.2 High head turbines, 3.1.4 Hydrokinetic units

Cécile Münch-Alligné obtained an engineering degree from INPG, Grenoble, France, department of Numerical and Modelling of Fluids and Solids, in 2002. She then obtained a grant from the CNRS and the CNES to start a PhD thesis on large eddy simulations of compressible turbulent flows. She defended her doctoral degree in 2005 at the INPG. From 2006 to 2010, she worked as a research associate in the Laboratory of Hydraulics Machines at EPFL on flow numerical simulations in hydraulic turbines. Since 2010, she has been Professor at HES-SO Valais-Wallis, School of Engineering in Sion, Switzerland.

She leads the hydroelectricity research group performing applied research in the field of small and large hydropower combining experimental and numerical approaches. She focuses on the development of new technologies for existing infrastructures such as kinetic turbines, turbines for drinking water network and small pumped storage power plants using existing réservoirs as well as the flexibility of small and large hydropower plants.

<https://www.hevs.ch/hydro>

<https://xflexhydro.net/>



**Prof. Dr. Peter Rutschmann**

Organisation: Technical University of Munich

Department of Civil, Geo and Environmental Engineering

Chair of Hydraulic and Water Resources Engineering

Edited chapter: 3.6 Fish passage technologies

Peter Rutschmann is a full professor at Technical University of Munich. He has 40 years of experience in hydraulic engineering and expertise in physical and numerical as well as hybrid modelling. He has managed some 50 hydropower projects, 35 sediment and flood management projects and also a few eco-hydraulic projects. He is one of the inventors of the innovative TUM hydroshaft powerplant and owns 8 patent families. Peter Rutschmann is a member of IAHR and the coordinator of the FIThydro project (Fishfriendly Innovative Technologies for Hydropower).

**Lea Berg**

Organisation: Technical University of Munich

Department of Civil, Geo and Environmental Engineering

Chair of Hydraulic and Water Resources Engineering

Edited chapter: 1.2.3. Fishfriendly Innovative Technologies for Hydropower

Lea Berg works at the Chair of Hydraulic and Water Resources Engineering of the Technical University of Munich. She is responsible for the communication, dissemination and exploitation of the EU-wide Horizon2020 project FIThydro and the regional test cases in Germany and Austria. Her background is in natural resources management, sustainable development and education with a Master of Science in Sustainable Resources Management from the Technical University of Munich and a Bachelor of Arts from Maastricht University.

*The Technical University of Munich – Chair of Hydraulic and Water Resources Engineering*

The Chair of Hydraulic and Water Resources Engineering has two affiliated laboratories, the Dieter-Thoma Laboratory in Munich and the Oskar von Miller Research laboratory, a hydraulic engineering research institute in Obernach, Bavaria, Germany. The primary focus of the research group of Professor Rutschmann and the affiliated laboratories is on teaching and carrying out research in the field of current and emerging hydraulic engineering technologies and water management. Research is conducted using hydraulic models as well as complex coupled three-dimensional flow programs. Hybrid modeling utilizing both approaches simultaneously is also used.

*FIThydro – Fishfriendly Innovative Technologies for Hydropower*

FIThydro is a 4-year Horizon2020 research and innovation project with 26 partners (13 research, 13 industry) from 10 European countries, involving several of the leading companies in the renewable and hydropower energy sector in Europe. The project's aim is to test and develop cost-effective environmental solutions, strategies and measures to ensure self-sustained fish populations and increase the ecological compatibility of existing and new hydropower schemes. For this, technologies, methods, tools and devices are applied and enhanced at test sites across Europe. The results from the research are combined in different, online accessible tools that help practitioners to evaluate, plan and find solutions for fishfriendly hydropower.

<https://www.fithydro.eu/>

**Vincent Denis**

Organisation: Mhylab, 1354 Montcherand, Switzerland

Managing director

Edited chapter : 1.3.2 Exploring Hidden Hydro, 3.1.2 High head turbines, 3.1.3 Medium and low head units, review of 3.1. Hydraulic turbines and gravitational hydropower machines

Vincent Denis holds a Master degree in mechanical engineering from EPFL (Swiss Federal Institute of Technology – Lausanne) with a specialization in hydraulic machines and fluid dynamics and got a prize for environmental contribution. Starting to work for an international swiss engineering company, he achieved a

second Master degree in energy systems from EPFL and other European universities (Swiss Federal Institutes of Technology - Zurich, Ecole Nationale Supérieure du Pétrole et des Moteurs - Paris, Imperial College of Medicine & Technology - London, Universidad Politécnica – Madrid, Technische Hochschule – Aachen).

Joining Mhylab in 1996 as R&D engineer in charge of the laboratory for hydraulic turbines, he developed the engineering and consultancy services of this newly founded company. Since then, he became managing director, still being strongly involved in hydropower projects as hydro and electromechanical equipment expert, particularly for overseas projects in Africa, Middle East and Oceania.

For more than 15 years, Vincent is also involved in teaching and training activities for Universities (EPFL, HES-SO, etc.) and within many projects including a capacity building phase. He is regularly appointed as evaluator for the European Commission support programs as Horizon 2020.

Fully dedicated to small hydro, *Mhylab* was founded in 1993 in Switzerland and provides services in the field of small hydro equipment along the axis of consultancy services, engineering and expertise, turbine & hydraulic machines design, development and testing according to IEC 60193 standard in its own laboratory located in Montcherand (Switzerland). For more than 20 years, Mhylab is involved in energy recovery project within existing infrastructures as for instance drinking water and irrigation networks, wastewater treatment plants, reserved flow and fish ladders, etc.

Since 2000, Mhylab's has engineering activities worldwide as for instance in Europe, (France, Italy, Romania, Switzerland, etc.), Africa (Burundi, Democratic Republic of Congo, Kenya, Madagascar, Rwanda, Tanzania, etc.), Oceania and Pacific islands (Australia, Vanuatu) and Asia (Japan, Jordan) as well for connected than for off-grid power generation.

<http://www.mhylab.com/home.php>



## Table of contents

<b>Foreword</b> .....	<b>3</b>
<b>List of Figures</b> .....	<b>9</b>
<b>List of Tables</b> .....	<b>12</b>
<b>Abbreviations, symbols and units</b> .....	<b>13</b>
<b>1 Introduction</b> .....	<b>17</b>
1.1 Introductory remarks .....	17
1.2 Small Hydropower as a vital element for national electrification .....	17
1.3 The innovative European SHP industry provides sustainable solutions .....	21
<b>2 Small Hydropower Systems</b> .....	<b>29</b>
2.1 Low head or high head .....	29
2.2 In-stream or diversion installations .....	31
2.3 Run-of-river or storage .....	34
<b>3 Overview of Hydropower System Components</b> .....	<b>37</b>
3.1 Hydraulic turbines and gravitational hydropower machines.....	37
3.2 Gearboxes .....	65
3.3 Generators .....	69
3.4 Electronic power conversion systems .....	71
3.5 Further electrical equipment and control systems .....	72
3.6 Hydromechanical steel works .....	75
3.7 Fish Passage Measures.....	86
<b>4 SHP Development Process</b> .....	<b>101</b>
4.1 Planning and Design Process.....	101
4.2 Permits and Licencing Process .....	104
4.3 Financial closure.....	104
4.4 Construction and commissioning .....	105
4.5 Operation & Maintenance (O&M).....	106
<b>5 Project Finance for international Small Hydropower Projects</b> .....	<b>107</b>
5.1 The Capital Asset Pricing Model.....	107
5.2 Project versus Corporate Finance .....	108
5.3 Funding sources .....	110
5.4 Public Sector Funding and EXIM Banks .....	111
5.5 Development Finance Institutes and Development Funds.....	112
5.6 Commercial Banks with the Use of Export Insurance.....	113
5.7 Bond Markets.....	114

5.8	Pension Funds.....	114
5.9	Other Funding Possibilities.....	114
5.10	Summary.....	116
<b>6</b>	<b>Conclusion .....</b>	<b>117</b>
	<b>List of references.....</b>	<b>119</b>

## List of Figures

Figure 1: Layout of a drinking-water network and possible positions of the turbines (Choulot, Denis and Punys, 2012) .....	24
Figure 2: Application range of various kinds of hydraulic turbines as offered by Escher Wyss, now Andritz Hydro (Raabe, 1985).....	30
Figure 3: Schematic of a small hydro diversion scheme (Gatte and Kadhim, 2012) .....	31
Figure 4: Run-of-river hydropower plant with a short diversion canal (EN 61116, 1992) .....	32
Figure 5: Malczyce SHP (9 MW) - Oder river, Poland (Wody Polskie, 2020).....	32
Figure 6: In-stream run-of-river SHP located at the left riverside (EN 61116, 1992).....	33
Figure 7: Shaping the inlet canal of Januszkowice SHP (1.5 MW) - Oder river, Poland (source: IMP PAN archives) .....	34
Figure 8: Schematic of a compact river cascade capable for swell operation without major water level variations at the intermediate stages (Michałowski and Plutecki, 1975).....	35
Figure 9: Schematic of a triple machine unit run in a hydraulic short-circuit system in Geesthacht PSPP (Germany). The same system can be replicated in a smaller scale (Bellmann, Sebestyen, and Wührer, 1999) .....	36
Figure 10: Normalised efficiency hill charts in the $(n_{HD}/n_{HD\ opt}, Q_{HD})$ plane for a Pelton turbine (a), low and high specific speed Francis turbine (b and c, respectively) and a Kaplan turbine (d). (Raabe, 1989) .....	38
Figure 11: Classic turbine types as dependent on the specific speed parameter (Raabe, 1989, after Voith) .....	39
Figure 12: Typical parameters of wind power rotors (Saini and Saini, 2019 after Menet, 2004, and Wilson & Lissaman, 1974) .....	40
Figure 13: Extensive cavitation damage at the suction side of a small Francis turbine runner (1970s, source: IMP PAN archives).....	41
Figure 14: Positioning of the reactive turbine reference levels. Arbitrary shaft axis orientation (IEC 60193, 2018) .....	43
Figure 15: Cavitation limit curves vs specific speed coefficient (after Arndt, 1981) .....	44
Figure 16: The 7 MW Pelton turbine of Gletsch Oberwald (CH) Hydropower plant (source: FMV SA).....	45
Figure 17: Schematic of single jet Turgo unit (Mala voda, 2020).....	45
Figure 18: A simplified Turgo turbine model (Hartvigsen Hydro, 2020) .....	45
Figure 19: An old fashioned small low head Francis turbine configuration (after Hoffmann (ed.), 1992) .....	47
Figure 20: A modern Francis turbine in a refurbished Polish hydropower plant (source: IMP PAN archives) .....	47
Figure 21: Typical efficiency curves of hydraulic turbines (Raabe, 1989) .....	48
Figure 22: Classic Kaplan turbine in siphon configuration. Marktbreit SHP (H =2.5 m, P =1100 kW) - Main, Germany (source: Raabe, 1985, after Voith) .....	48
Figure 23: Schematic vertical section of a low head SHP with an S-type tubular turbine. (After IEC 61116, 1992) .....	49

Figure 24: An inversed propeller or semi Kaplan turbine in a double elbow siphon configuration (ESHA, 2004) .....	50
Figure 25: Semi Kaplan turbine in a single elbow siphon configuration (ESHA, 2004).....	50
Figure 26: Kaplan turbine in SAXO configuration (Gale et al., 2010) .....	50
Figure 27: Comparison between excavation work needed for classic Kaplan turbines (2 units) and 4 tubular SAM turbines (4 units) with the same total capacity (Czerwinski, Canas, and Marin, 2012) .....	50
Figure 28: Tubular Kaplan turbine in pit arrangement (ESHA, 2004).....	51
Figure 29: A compact semi-Kaplan unit with bevel speed increaser (ESHA, 2004).....	51
Figure 30: A typical compact unit with bevel speed increaser. Oborniki SHP, Poland (source: IMP PAN archives) .....	51
Figure 31: Hydromatrix® axial-flow units as offered by Andritz for installation in locks or weir gates (Cui, Binder and Schlemmer, 2007) .....	52
Figure 32: A VLHT unit at outlet of the Milleau canal (Leclerc, 2008) .....	52
Figure 33: The Mhylab diagonal turbine (Denis, Cottin and Choulot, 2016) .....	53
Figure 34: The Mhylab diagonal turbine (Bullani and Denis, 2019).....	54
Figure 35: Cross-flow turbine according to the Ossberger concept (Ossberger, 2018).....	54
Figure 36: Pumps for turbine operation as offered by KSB AG (KSB, 2012).....	56
Figure 37: Duo Turbo turbine developed at HES SO Valais (Biner, 2016).....	56
Figure 38: A water wheel unit model by a Bavarian company of Walter Schumann at the annual RENEXPO Interhydro fair in Salzburg, Austria (source: J. Steller).....	57
Figure 39: Non-ducted turbines with horizontal and flow adapting axis (Khan, 2009).....	58
Figure 40: Vertical axis kinetic turbine (Khan, 2009) .....	58
Figure 41: Strom Boje 3 unit (source: Aqua Libre Energieentwicklungs GmbH).....	61
Figure 42: Tailrace channel of Lavey HPP with the open-air platform to test the kinetic turbine prototype (Munch et al., Water 2018) .....	61
Figure 43: Hydroquest technology tested in France (HydroQuest, 2020) .....	62
Figure 44: Schematic view of an Archimedes screw runner showing instantaneous positioning of water in "buckets" formed by the screw blading (Rohmer et al., 2016).....	63
Figure 45: A parallel Archimedes screw set by Rehart Power (left) and a 3D view of Hydroconnect coaxial screw unit (right) at the RENEXPO Interhydro Fair in 2017 (source: J. Steller) .....	64
Figure 46: Steffturbine™ hydropower engine (Baselt, Malcherek and Maerker, 2013).....	64
Figure 47: Tubular pit turbine with a bevel speed increaser (Voith, 1990s).....	65
Figure 48: Vertical Kaplan unit with a parallel shaft speed increaser (Eisenbeiss, 2016) .....	65
Figure 49: Spur gears dedicated for (left) vertical Kaplan and (right) pit tubular turbines (Eisenbeiss, 2016) .....	66
Figure 50: Bevel gears driving a horizontal (left) and vertical (right) generator (Eisenbeiss, 2016) .....	66
Figure 51: A double sun planet gear as offered by Rohloff AG (2020) .....	66

Figure 52: Application range of 3 types of transmission belts as offered by Hutchinson (2020).....	67
Figure 53: Flat belt drives in micro hydropower installations (Burger Wasserkraftanlagen, 2020).....	68
Figure 54: A mini straflo unit with combined power transmission from the runner rim by means of a flat belt and a spur speed increaser (ESHA, 2004).....	69
Figure 55: Asynchronous generator (Little, 2016).....	71
Figure 56: Schematic of a power electronics unit with a thyristor or an active IGBT rectifier and an IGBT inverter (Sobczyk et al., 2010).....	72
Figure 57: Electrical system schematic of an SHP power blocks in Southern Poland. A screenshot taken at standstill from the power plant supervision and control system (Courtesy of PGE EO SA).....	74
Figure 58: Unit 1 hydraulic control system schematic of an SHP of Figure 53. A screenshot taken immediately after shutdown from the power plant supervision and control system (Courtesy of PGE EO SA).....	74
Figure 59: Articulated trash rack cleaner in Januszkowice SHP - Oder river, Poland (source: J. Steller).....	76
Figure 60: Aquashear Coanda screen (Dulas Ltd, 2020).....	76
Figure 61: The Rutki SHP water intake - Radunia Cascade, Poland (source IMP PAN archives).....	77
Figure 62: A small hydropower plant with two submersible Flygt and cylindrical intake gates (Flygt, 2020).....	78
Figure 63: Segment (Tainter) gate (USACE, n.d.).....	79
Figure 64: Weir crest hinged flap gate at Rzeczyca SHP - Wierzyca river, Poland (source: J. Steller).....	79
Figure 65: Fish belly flap hinged to a Tainter gate edge. Perach HPP - Inn river, Germany (Raabe,1985).....	79
Figure 66: Inflated weir principle of operation (Daniel & Paulus, 2019).....	80
Figure 67: Inflatable weir in winter and summer seasons, Kliczkow SHP - Kwisza river, Poland (Polniak, 2015).....	80
Figure 68: Hydroplus classic fuse gate. Principle of operation (Hydroplus, 2020).....	81
Figure 69: A spring weir principle of operation and existing installation at Hausach - Kinzig, Germany (Wiegand, 2020).....	81
Figure 70: Tensile effort (MN/m <sup>2</sup> ) distribution at penstock branching node (Adamkowski et al, 2019).....	82
Figure 71: Typical steel and ductile iron penstock small hydro application ranges (Steller, 2020 after anon).....	83
Figure 72: Typical steel and ductile iron penstock joints: a) welded joints; b) gland joints; c) flange joints; d) spigot joints; e) threaded spigot joints (Giesecke & Mosonyi, 1998).....	83
Figure 73: Flowtite pipe structure (left) and replacement of a wood stave penstock segment by a Hobas GRP pipeline (right). Jackman Hydro Station, Hills-borough, New Hampshire, USA (Amiblu, 2020).....	84
Figure 74: Butterfly valves as offered by the TB Hydro company (TB Hydro, 2020).....	85
Figure 75: Rotary and globe valves as offered by the TB Hydro company (TB Hydro, 2020).....	86
Figure 76: Pool type (left) and steep baffle type (Denil) fish pass (right) (source: J. Geist, P. Rutschmann).....	88
Figure 77: Combination of different types of ramps, with concrete elements in the foreground and steep, rough ramp in the background (source: P. Rutschmann).....	89

Figure 78: Nature like fishway at Freudenua HPP, Austria (source: W. Reckendorfer) .....	89
Figure 79: Eel ramp covered by a brush type substrate (left) and (right) a concrete cones substrate (source: AFB) .....	90
Figure 80: Fish lift Runserau, Austria (source: M. Schletterer) .....	90
Figure 81: Fish lock at the Jeging 2 HPP, Austria. (source: M. Schletterer) .....	91
Figure 82: View of fish-friendly turbines: screw (up left), VLH (up right) (source: MJ2 technologies), Pentair fair-banks (down left) and Alden turbine (down right).....	93
Figure 83: IDA pilot at the 35 kW test case Kaplan turbine intake with the two ring-shaped copper electrodes (left) and observed damage rates for fish passage without (blue) and with IDA pilot device (red) for varying fish lengths (total length TL) .....	94
Figure 84: Skimming wall at Bellows falls power station (Odeh, et al., 1998) .....	95
Figure 85: Conceptual plan of the location of downstream bypasses at hydroelectric plant intakes (from Larinier, et al., 2002) .....	96
Figure 86: Longitudinal view of an inclined bar rack (source: Courret, et al., 2008) .....	97
Figure 87: Inclined bar rack with openings to the bypass channel system (source: P. Rutschmann) .....	97
Figure 88: The horizontal bar rack of residual flow HPP Schiffmühle, Switzerland, during reservoir drawdown in July 2018 (source: J. Meister, VAW) .....	98
Figure 89: Detailed geometric view of louver, angled bar rack and modified angled bar rack (MBR) (from Boes, et al., 2017).....	98
Figure 90: a) “classical” angled bar rack, and b) angled bar rack with bars in the streamwise direction (from Raynal, et al., 2014) .....	99
Figure 91: Coanda water intake illustration and example of Coanda water intake of Escouloubre (977 m altitude) on the Aude river, France (Source: AFB).....	99
Figure 92: Visualization of the Hydro Shaft Concept (top line) and 450 kW at Grossweil, Germany (bottom line) (Source: top line: TUM and bottom line: A. Sepp) .....	100
Figure 93: Perfect and Imperfect Markets (1to3 Capital).....	110

## List of Tables

Table 1: Examples of Mini-Grid Operators (EREF, 2020).....	20
Table 2: Non-dimensional and dimensional performance parameter factors (IEC 60193, 2018) .....	37
Table 3: The equivalent head, power flux density and maximum output to be expected from highly efficient non-ducted hydrokinetic propeller turbines of various tip diameters.....	60

## Abbreviations, symbols and units

Abbreviations	
AC	Alternating current
AFD	French Development Agency
AFDB	African Development Bank
BDS	Barotrauma Detection System
BioPA	Biological Performance Assessment
BPS	Basis points
CAE	Computer-aided engineering
CAM	Computer-aided manufacturing
CAPM	Capital Asset Pricing Model
CASiMiR	Computer Aided Simulation Model for Instream Flow and Riparia
CBR	Curved-Bar Racks
CFD	Computational Fluid Dynamics
CFRP	Carbon fiber reinforced plastics
D:E ratio	Debt:equity ratio
DC	Direct current
DFI	Financial development institutions
DFI	Development finance institutes
DSCR	Debt service coverage ratio
DSS	Decision support system
DWTP	Drinking water treatment plants
e.g.	Exempli gratia - for example
EASE	European Association for Storage of Energy
ECA	Export credit agency
EERA	European Energy Research Alliance
EIB	European Investment Bank
EN-ISO	European Standard-International Organization for Standardization
ERA	European Research Area
EREF	European Renewable Energies Federation
etc.	Et cetera – and so forth
EU	European Union
EUR	EURO
FEM	Finite element method
GFRP	Glass fiber reinforced plastics
GPS	Global Positioning System
GRP	Glass reinforced plastics
H2020	Horizon 2020 (a EU funding programme)
HDPE	High density polyethylene
HPP	Hydropower plant

<b>HVOF</b>	High-velocity oxygen-fuel spraying
<b>i.e.</b>	Latin: „id est“ – meaning „that is“
<b>IBRD</b>	International Bank for Reconstruction and Development
<b>ICOLD</b>	International Commission on Large Dams
<b>IDA</b>	International Development Association
<b>IFC</b>	International finance corporation
<b>IGBT</b>	Insulated-gate bipolar transistor
<b>IHA</b>	International Hydropower Association
<b>IPP</b>	Independent power producer scheme
<b>IRENA</b>	International Renewable Energy Agency
<b>LCOE</b>	Levelised cost of electricity
<b>MBR</b>	Modified angled bar rack
<b>MFIs</b>	Multilateral finance institutions
<b>MGR</b>	Minimum gap runner
<b>MIGA</b>	Multilateral investment guarantee agency
<b>NGO</b>	Non-governmental organisation
<b>O&amp;M</b>	Operation and maintenance
<b>ODA</b>	Official development aid
<b>OECD</b>	Organisation for Economic Co-operation and Development
<b>PAT</b>	Pump as turbine
<b>PE</b>	Polyethylene
<b>PLC</b>	Programmable logic controller
<b>PPA</b>	Power purchase agreement
<b>PSP</b>	Pumped-storage power
<b>PSW</b>	Private sector window
<b>PURPA</b>	Public Utility Legislation Policies Act
<b>PVC</b>	Polyvinyl chloride
<b>R&amp;D</b>	Research and development
<b>RCC</b>	Reinforced cement concrete
<b>RE</b>	Renewable energies
<b>RES</b>	Renewable energy sources
<b>RIA</b>	Research and Innovation Agenda
<b>SAM</b>	S-shaped Axial Machine (turbine) with an upstream elbow
<b>SAXO</b>	“SAXOphone”-shaped tubular turbine
<b>SHP</b>	Small hydropower
<b>SIR</b>	Strategic industry roadmap
<b>SMEs</b>	Small and medium enterprises
<b>SPC</b>	Special purpose vehicle/company
<b>SSA</b>	Social security administration
<b>Straflo</b>	Straight flow (turbine)
<b>TUM</b>	Technical University of Munich



US	United States (of America)
USACE	United States Army Corps of Engineers
USD	US dollar
VLHT	Very low head turbine
WACC	Weighted-average cost of capital
WBG	World Bank Group
WFD	Water Framework Directive

Symbols	
$A$	Area
$B$	Width
$\beta$	Angle
$c$	Sound celerity
$CO_2$	Carbon dioxide
$D$	Time/duration, hours
$D$	Diameter
$E$	Specific energy, J/kg
$\varepsilon$	Raw power density
$f$	Power capacity surplus ratio
$f$	Frequency
$g$	Acceleration of gravity
$\bar{g}$	Average acceleration of gravity
$H$	Net head
$H_s$	Suction head
$I$	Electrical current
$n$	Rotation speed
$n_Q, n_{SQ}, n_{SP}$	Specific speed (various definitions)
$NPSH$	Net positive suction head
$P$	Power (mechanical or active electrical)
$p$	Number of poles in a generator
$p_{abs}$	Absolute pressure
$p_{va}$	Saturated vapour pressure
$Q$	Reactive electrical power
$Q$	Volumetric flow rate/discharge
$\cos \varphi$	Power factor
$\sigma_{Th}$	Thoma cavitation number
$S$	Apparent electrical power
$T$	Torque
$TSR$	Tip speed ratio
$U$	Voltage
$v, V$	Flow velocity

$\omega$	Angular velocity, rad/s
$z$	Elevation
$\eta$	Efficiency
$\rho$	Liquid density

Units	
°	Degree
%	Percentage
a	Year
A	Ampere
GPa	Gigapascal
GW	Gigawatt
GWh	Gigawatthour
h	Hour
HP	Horsepower
kGm	Kilogramme-metre (outdated unit of mechanical moment)
km	Kilometre
kW	Kilowatt
l	Litre
m	Metre
m <sup>3</sup>	Cubic metre
mm	Millimetre
MW	Megawatt
MWh	Megawatthour
Nm	Newton metre
rpm	Revolutions per minute
s	Second
V	Volt
VAr	Volt-Ampere (reactive power unit)
W	Watt

# 1 Introduction

## 1.1 Introductory remarks

Hydropower, especially Small Hydropower (SHP), has already shown in the past that it can play a decisive part in electrifying regions. It was not the first, however among the sources that enabled first electrification and electricity grids in Europe at the end of the 19th century. Major milestones (Walcher, 2020) included the first hydroelectric installation in Northumberland (England) in 1880, and the first three-phase current long-distance transmission from a hydropower plant, from Lauffen/Neckar to Frankfurt/Main (Germany) in 1891 for demonstration purposes during the World Expo in Frankfurt (Wessel (ed), 1991). And some years later, with the commissioning of Wynau HPP (Switzerland) in 1896, Paderno d'Adda HPP (Italy) and Rheinfelden HPP (Swiss/German cooperation) in 1898, the history of modern European power grids was initiated (VDE, 2015). The technology was developed to very high standards in terms of efficiency, security and reliability and is used nowadays around the world.

In recent years, hydropower was identified as indispensable element of the global energy system transformation (IRENA, 2019) and has grown around the world. Today, SHP is normally used in conditions, when large hydropower cannot be deployed, tapping also the sustainable potential that otherwise could not be used. Although being a clean energy source, hydropower and especially SHP have seen scrutiny and opposition in many cases when hydropower plants were erected without considering the latest technology and thus not providing all benefits it can.

The European hydropower industry offers the complete range of solutions and services to harness the potential of hydropower in a sustainable way, indeed for almost any conditions. Most important, European equipment distinguishes itself with a very high efficiency and can comply with even the strictest environmental laws and regulations. In the following chapters, together with general technical and historical information, information is given about these solutions to show how the European hydropower industry can contribute to sustainable energy provision.

This handbook is not meant as recommendation to buy equipment only at the mentioned companies. In fact, the providers of the sustainable hydropower solutions are located across Europe and in business contacts should be made individually. The HYPOSO project provides therefore a list of public available contacts of the European hydropower industry:

<https://www.hyposo.eu/en/sector-information/sector-sector-information-europe/> .

Furthermore, interested stakeholders from Europe and from the HYPOSO target countries Bolivia, Colombia and Ecuador in Latin America, and Cameroon and Uganda in Africa, are invited to participate at the so-called HYPOSO Platform which provides more information and is aimed at fostering business contacts in the sector:

<https://www.hyposo.eu/en/hyposo-platform/> .

## 1.2 Small Hydropower as a vital element for national electrification

### 1.2.1 Grid connected

Although many times being thought of as the perfect solution to electrify remote areas, in many cases Small Hydropower (SHP) is also a valuable contributor to grid stability in existing grids, be it in the form of steady base load generation from run-of-river plants, or as grid-stabilizer in the form of hydropower cascades in swell operation, storage installations and even pumped-storage power (PSP) plants. Especially, when countries need or want to develop locally balanced grids, integrating intermittent renewable energy sources like wind or solar installations, the benefits of SHP become visible.

SHP is a renewable energy source with low volatility and shows a beneficial impact on electricity grids, because it can feed-in a continuous output for a predictable period of time. The installed power use duration (in full load hours/year) depends on the installation type and water supply for hydropower generation. Generally, the plants used for regulation purposes and run-of-river ones in mountainous or sub-mountainous regions show low value of this parameter in distinction from the run-of-river ones located on water courses with high flow rate stability. The Stream Map project (ESHA, 2012) published for SHP an average number of 3,252 full load hours for the EU-27 (then with the UK but without Croatia), which is higher compared with other renewable sources like wind (2,000 full load hours) and solar (914 full load hours) power plants. Recently, studies have been carried out in France (France Hydro Electricité, 2020) and Germany (Zdrallek, 2018) to investigate in detail the impacts of SHP to electricity grids.

According to the calculations by Zdrallek (2018), in Germany (considered were 7,000 SHPs, each with a capacity < 1 MW) 750 million EUR of additional needed costs for grid extension in the medium and low-voltage grid would need to be invested, if instead SHP, volatile renewable energy sources like wind power or PV should provide the same capacity. Furthermore, the grid expansion of distribution grids can be considerably reduced as the construction of thousands of kilometres of power lines can be avoided. If SHP are built in vicinity of the electricity consumers, as well network losses are reduced significantly. Through the good controllability, SHP can actively support maintaining the frequency and stabilizing the overall system (providing the so-called regulatory power). This fact plays especially a big role, when other conventional (fossil) energy sources are to be replaced. Due to the good controllability (active and reactive power), SHP furthermore can contribute to the important supply and voltage quality in distribution grids.

If modified, SHP can also play the role of controllable and decentralized generators and can supply local mini grids (e.g. critical infrastructure like emergency services sectors) also in case of extensive blackouts. Not only storage plants, even run-of-river power plants could be used (without a loss of efficiency) as decentralised energy stores, when storage capacity in river impoundments is managed dynamically. In addition to the benefits for the grid, SHP and other HPP have another major benefit. Because of the relatively simple and robust construction, low maintenance costs arise and a long operating time (> 50 years) is possible, which leads to very low electricity generation costs.

Of course, the absolute numbers shown here go only for Germany, and it needs to be stated that the operation conditions for SHP in Germany are the best in Europe. Thus, benefits can most probably be achieved, however not in the same dimensions as presented here.

According to the French study (France Hydro Electricité, 2020), which focused on the role of France in the European power system, hydropower plays a primordial role for flexibility, providing a buffer for structural variation of the residual demand, covering residual demand forecast errors and providing rapidly dynamic contingencies. Without hydropower the system could not be maintained. To some extent, in an integrated scenario of the future of the European grid (for 2050), SHP can play a similar role as batteries regarding their modulation potential. SHP can furthermore have a business future if being used as ramping or new frequency reserve products, or as a local flexibility platform. Long term ancillary services and flexible capacities could be tendered and also scarcity pricing should be considered. What needs to be thought of still, is a fair and specific remuneration of the services provided by hydropower, which will be needed more in the future.

### 1.2.2 Captive power supply

The concept of Captive Power Plants is of growing importance on an international level especially in regions with unreliable grid supply (blackouts, brownouts, load shedding etc.), high grid tariffs/uncertain tariff developments or off-grid scenarios. In some regions, Captive Power Plants are also known as embedded generation, which could in some countries, however, be misinterpreted for power plants embedded in distribution grids.

Agricultural, commercial, or industrial companies are relying heavily on a reliable supply of sufficient energy to maintain a profitable and competitive operation. Therefore, instead of relying only on the grid supply, they are increasingly looking for dedicated power plants on or near their premises to cover their energy requirements. Captive Power Plants usually have a smaller generation capacity as they focus on the load demand of the specific target company only. Whether these power plants are:

- grid connected or operating off-grid
- owned and maintained by the company (prosumer) or supplying energy to the company as an off taker

depends on the individual project situation and/or the national regulatory regime.

While such power plants have in the past used fossil fuel generators (Diesel gensets) they are continuously being refurbished and now initially equipped with renewable energy sources to:

- decrease dependency on fossil fuel, which must be delivered to the power plant on a continuous basis;
- save costs as the Diesel prices are going up;
- enhance the green footprint of the corporate consumer.

The selection of the renewable energy source depends on the location of the plant. While some areas are perfect for PV or wind power plants, SHP is an excellent option where adjacent rivers offer a good energy potential. The agricultural industry, for example, is often operating near rivers which could be used for energy generation.

An example is the Kenya Tea Development Agency (KTDA), the single largest tea producer in the world, is increasingly relying on small hydro power for their tea factories. Through their wholly own subsidiary the KTDA Power Corporation (KTPC) they invested and manage in the first phase the 5.8 MW Gura SHP, the 5.6 MW North Mathi-oya SHP and the 0.9 MW Chania SHP. There are more sites identified, which would have a good SHP potential in the next phase.

The 5.8 MW Gura SHP-Plant is located high up in the Gura Valley in Nyeri County/Central Kenya. It was built in 2016 and delivers a total of 18 GWh of electric power on an annual basis. The generated energy covers the energy demand of the 4 tea factories in Iriaini, Chinga, Gathuthi and Gitugi. The surplus energy is fed into grid of the state-owned utility KPLC under a power purchase agreement (PPA). Therefore it secures extra revenue to KTDA and enhances the stability of the public grid in the surrounding areas.

Before the installation of the Gura SHP the factories were relying on the unstable public grid and Diesel gensets, which were used during the constantly occurring grid outages (Liu et al., 2019).

Another technical approach in this regard is to generate energy based on recovery of energy lost in various technological processes. This kind of technical options are discussed in more detail in section 1.3.2 (Hidden Hydro) and at some further sites of this handbook.

### 1.2.3 Mini-Grids

The national grid development approach is usually focussing on achieving a single interconnected national grid with huge power plants feeding into the national transmission grid to provide energy to the distribution grids. Economies of scale and a full national electrification can be easily achieved, as well as the investment cost recovered when having a high population density as well as economically attractive consumption loads.

Such an approach, however, can be a challenge for countries with low population density especially in rural areas and with consumers having only small loads: A low population density results in high specific grid connection cost for individual households. In combination with a small monthly revenue it might take a long time for grid operators to recover the related investment cost (in some cases more than 20 years).

Long transmission lines to bridge unpopulated areas and/or difficult geographic terrains to serve small communities beyond might not be economically viable.

However, as electrification drives the economic development it is an important determining factor to raise the prosperity level. Especially emerging and developing countries face economically difficulties to connect remote settlements through a centralised grid, which results in unconnected and underdeveloped regions. As example, in the Sub-Saharan Region about 57 % of the population, i.e. 612 million people, had no access to electricity by end 2018.

This is where the Mini-Grid concept can be applied, which is based on an independent grid serving power consumers within defined boundaries. Mini-Grids are typically isolated far away from the central grid in remote areas but could also be grid-connected in regions with an insufficient and unstable power supply. Grid connected Mini-Grids switch to island mode once the central grid fails.

There are various business models for the operation of Mini-Grids (Table 1) possible which can be summarised as follows:

**Table 1: Examples of Mini-Grid Operators (EREF, 2020)**

<b>Private Sector Investors</b>	Investments might be made through Special Purpose Vehicles (SPV) having various shareholders; based on a licence/concession obtained from the regulatory authorities.
<b>Energy Communities</b>	Emerging concept which might be included in the regulatory framework; strong commitment from the benefiting community.
<b>Public Utilities</b>	Might act in line with a universal service obligation; electric power for the mini-grid could be bought from an Independent Power Producer (IPP).

Especially *Energy Communities* can be a driving force for Mini-Grids as they are slowly considered in national energy regulations also.

While the Mini-Grids emerged initially in a legally grey area, countries are slowly considering them in their regulatory framework and as part of their national electrification strategy to boost rural electrification.

The power generation is the heart of the Mini-Grid which can consist of a single unit or multiple electric power generation plants. There is no clear capacity range defined for Mini-Grids, with different sources using different ranges, however, one of the commonly used capacity range definition is 10 kW to 10 MW (MGP, 2020).

Diesel generators used to be a core generation system in Mini Grids. However, as they increase the CO<sub>2</sub> burden and require a constant supply of expansive fuel, renewable energy sources are slowly taking over. Where suitable hydrologic conditions are available the Small Hydro Power (SHP) segment is a perfect alternative to provide a reliable supply of renewable energy. The emerging kinetic turbines might offer even more flexibility to increase the applicability of SHP in Mini-Grid scenarios (see chapter 3.1.4 of this handbook for more details).

The implementation of hybrid generation systems to reach a stable renewable power supply is increasing as the required control and power management systems have reached technical maturity. SHP can operate stand-alone alone or in a hybrid-system, for example, with PV-Solar to address seasonal fluctuation and peak demand.

An example is the Mini Grid in the Ludewa District in Tanzania (ACRA, 2020) supplying hydroelectric energy to 20 isolated rural villages and connecting 4,000 households with approx. 51,000 people as well as 340 SMEs, schools and a hospital plus health services. The implemented SHP has a capacity of 1.7 MW with a total annual production capacity of 9,000 MWh and replaced various highly polluting individual Diesel gensets in the villages. The project is managed by an Energy Users Entity (EUE).

It should be noticed that even in countries with national grids covering whole or almost whole territory the mini-grid concept finds ever more wide interest as rapid development of distributed intermittent electricity sources raises demand for local balancing of grid parameters. The response are energy clusters supplying the so-called smart grids. The smart grid concepts generally assume some energy storage capacities provided by batteries and storage or even pumped storage SHPPs. The advantage is not only increased inertia of the national grid portion and decrease of energy losses due to long distance transmission of regulation power, but also increased electricity supply safety as the concept assumes usually isle operation in case of a large scale black-out.

### 1.3 The innovative European SHP industry provides sustainable solutions

#### 1.3.1 Innovative strength of the European Small Hydro Industry

Hydropower has been an important component of European industrial identity since ancient times. A direct link between hydropower and the more or less institutional world of science can be counted at least since the times of Leonhard Euler, an 18th century Swiss born genius and father of the hydraulic turbine theory. While the 19th century saw parallel development of hydropower industry at both sides of the Atlantic ocean with two significant turbine types (Francis and Pelton) invented in the US, it was in Europe where the first long distance electricity transmission took place, the third most significant turbine type (Kaplan) was developed later on and three giant manufacturing companies emerged. The systematic technological development having taken place over the previous century has covered all aspects of hydropower industry including civil, hydraulic, mechanical and electrical engineering. Due to high significance of the sector and high level of competence required, relevant technical courses were introduced at most European technical universities and numerous technical colleges. The universities took over also a major part of necessary research and partially also research and development effort with Lausanne, Zurich, Grenoble, Munich, Stuttgart, Trondheim and some other locations in the foreground. The hydropower industry concentrated mainly in Alpine countries (especially France, Germany, Switzerland and Austria), but also Scandinavia (Norway and Sweden) and the former Soviet Union (today: Russian Federation and Ukraine). Manufacturers of various size and numerous consulting and engineering offices are active today also in the Czech Republic, Slovenia, Italy, Poland and some other countries.

The incomprehensive list of main technological progress having taken place over the recent decades includes:

1. widening the operating range and the capacity regulation capabilities as well as increasing specific speed and efficiency of hydraulic units - both by optimising the flow system geometry and introducing the variable speed technology;
2. enhancing cavitation properties of hydraulic turbines and improving their resistance to erosive surroundings (by various techniques, including adequate shaping of the flow system, introducing additional arrangements such as anti-cavitation strips at the runner blade edges and partial load rope disintegrating fins within the turbine suction area, by air injection systems and finally - by applying erosion resistant materials and protective coatings spread by innovative techniques);
3. new design and increased technical parameters of such crucial structural hydraulic unit nodes as bearings, seals, regulation mechanism actuators and relevant safeguards;
4. new electrical equipment technology, including generators with variable speed operation capabilities as well as electrical switch board and safeguard equipment;
5. introducing the completely new regulation and control system technology, allowing for unmanned operation with remote supervision of both hydraulic units and the whole hydropower installations or even river cascades;

6. new auxiliary equipment and technologies, including inflatable weirs, valves and gates, trashrack cleaners, upstream and downstream fish passage systems, such as passive and active fish ladders, fish guiding barriers etc.

The main stimulus for enhancing the performance and cavitation properties of hydraulic turbines by optimising the flow system geometry was the progress in the CFD and other related flow analysis and computerized design techniques, including solving the inverse problem in fluid mechanics as one of the flow system design approaches. The achievements in other directions have appeared possible as a part of the general progress in technical sciences and in particular as an implementation of new ideas in such technological branches as material science and machinery manufacturing technology (including CAM and more generally – CAE techniques), fluid control technology (including high pressure hydraulic systems) and electrical engineering, including electrical power electronics. A profound impact on all the aspects of hydropower engineering was exerted by dynamic development of computer science and related digital technologies.

In addition to the rising technical requirements following mainly from economic reasons and strong European market competition, a significant impulse for progress in numerous directions came from ever more stringent environmental requirements. These have led in particular to replacing traditional oils in the lubricated systems by biodegradable ones and complete removal of oil from numerous shaft and guide vane bearing systems.

The environmental constraints have substantially confined new large hydro projects in Europe directing most of equipment production to other continents. In practice, only the projects representing a part of major schemes oriented on substantial reduction of environmental burdens by other sectors (e.g. by taking over a part of land road transport by inland navigation) or on mitigation of climate change effects (e.g. by flood protection as well as water and energy storage) have a realistic chance to be pushed forward.

The situation is different with small hydropower sector (up to 10 MW capacity according to the EU statistics and legislation) where ever rising environmental constraints have still left space for innovation or even stimulated completely new designs. In particular, the support from public means has allowed to develop a number of innovative low head and hydrokinetic units, some of them especially attractive for non-European markets with possible application at sites with no access to the national grid.

The significance of hydropower both as a contributor to the green electricity mix and ever more importantly as a regulating tool in the grid operator hands is ever more recognized in the EU and other countries linked with EU by various more or less tight collaboration schemes, such as. The significance attributed to the sector by the European Commission is clearly demonstrated by direct contact with such hydropower related global and European associations as IRENA, Eurelectric, and the EREF Small Hydropower Chapter. Hydropower is well visible in various initiatives undertaken within the European Research Area (ERA) which in addition to the EU Member States includes also such hydropower heavy weight players as Norway, Switzerland and Turkey.

One of recent initiatives within the ERA is establishing the Joint Project “Hydropower” within the European Energy Research Alliance (EERA) which is an umbrella body grouping European research centres and universities with the mission to catalyse energy research for a climate-neutral society. The main purpose of the “Hydropower Joint Project” is to facilitate collaboration and coordinate research activities in order to raise their effectiveness. A current initiative of even higher strategic significance for the whole sector is the “Hydropower Europe” project sponsored within the Horizon 2020 framework research programme. The key purpose is developing the hydropower related Research and Innovation Agenda (RIA) and the Strategic Industry Roadmap (SIR) for the next financing perspective.

In addition to projects aimed at providing the European Commission with analyses necessary for rational strategy towards the sector, numerous R&D and demonstrative projects are in progress, just to mention HydroFlex (Increasing the value of Hydropower through increased Flexibility), AFC4Hydro (Active Flow Control system FOR improving HYDRaulic turbine performances at off-design Operation), ALPHEUS (Augmenting grid stability through



Low-head Pumped Hydro Energy Utilization & Storage), XFLEX HYDRO (Hydropower Extending Power System Flexibility), FITHydro (Fish friendly Innovative Technologies for Hydropower), SHYDRO-ALP, DAFNE, KEEPFISH, Hykinetics as well as HYPOSO and RES-34-2020 promotive and demonstrative projects (Schleker, 2020). As it can be seen, rising hydropower technical capabilities to contribute to grid flexibility is considered high priority both for large and small hydro. Another key research and development objective is increasing hydropower sustainability by minimising unwanted environmental impacts on biodiversity and biological continuity. Among other strongly supported development trends one should mention also implementation of small hydro technology for recovery of energy lost by throttling in industrial and municipal hydraulic systems. These and a lot of more detailed research and development trends add to high quality of the European small hydro related industrial offer. The main areas of this offer will be briefly characterised in the next two chapters.

### 1.3.2 Exploring Hidden Hydro

The term “hidden hydro” addresses often this part of hydropower potential which is either based on the data not included in the national hydropower potential surveys or can be used in a more rational way than nowadays.

#### 1.3.2.1 Energy Recovery and Harvest

The first group refers in particular to:

1. energy recovery in industrial and municipal hydraulic systems;
2. energy recovery in irrigation systems;
3. energy recovery in desalination stations and other industrial systems;
4. residual flow outlets at existing dams and weirs;
5. energy recovery in fish bypass systems;
6. energy harvest in navigation lock gate bypass conduits;

An extensive overview of these and other opportunities to extract energy out of flow systems in existing water infrastructure was given by Choulot, Denis, and Punys (2012), and when Choulot, Denis et al. gave an overview of the best practises and set of 24 case studies in Europe (2010).

#### Municipal Drink and Wastewater Systems

Energy recovery of hydraulic energy lost in municipal hydraulic systems is the most apparent kind of hidden hydro. The interest in such systems can be dated at least since the 1900s (Sonzier hydropower plant, Switzerland) and was initially limited to mountainous, mainly Alpine, countries where especially favourable conditions existed due to substantial differences in altitude of possible energy recovery sites (Figure 1). The pressure at inlet to the drinking water treatment plants (DWTP) or storage reservoirs appears often too high and has to be reduced using pressure reduction valves or break pressure tanks which can be replaced by the hydraulic energy recovery units. The most notable example of such an installation is the Mühlau power plant with 5,750 kW capacity and ca 450 m head. The plant is owned by the Innsbruck Municipal Works (Austria) and was commissioned as early as 1951.

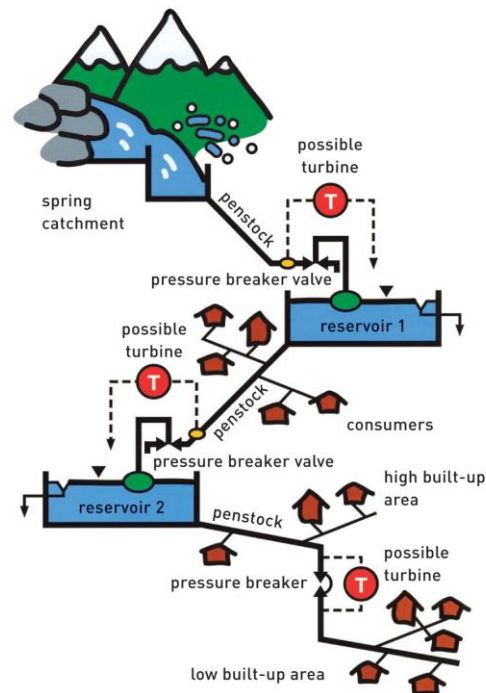

**Figure 1: Layout of a drinking-water network and possible positions of the turbines (Choulot, Denis and Punys, 2012)**

The need of pressure reduction may occur also at some other sites of the municipal water networks, including inlet to the water supply network or a part of it.

Waste water outlets from the waste water treatment plants are also in the focus, as they offer also substantial potential (Bousquet et al., 2017). Waste water turbinng before treatment is also possible, as it is the case in Le Châble in Switzerland, where the wastewater collected in the ski resort of Verbier is turbinng before entering the wastewater treatment plant set in the valley. With a head of 450 m, the installed capacity is 380 kW with a production of around 0.85 GWh/year. Another relevant example is the As Samra site in Jordan, where two turbines are installed before the inlet of the wastewater treatment plant (2 x 830 kW, 104 m) and three at the outlet (2 x 750 kW and 1 x 490 kW, 42 m). Altogether, the five turbines are producing around 19 GWh/year (Denis, 2019).

Generally, Pelton turbines are preferred as long as the flow and head suits to this type of turbines, the advantage being their capacity to follow the flow changes all along the day. Francis turbines are also often used in case of medium heads and flow. Pumps in turbine operation regime (see section 3.1.3) can be used for sites with potential up to 100 kW and with fixed flow, considering the absence of flow regulation possibility and low efficiency. As it is the case for any hydropower project, the choice of the appropriate turbine type will always be the result of a technical and economic analysis.

Hydraulic energy recovery from municipal networks gains an ever more rising interest in Europe and is supported by a number of European projects, such as HYDRO-BPT, LifeHyGENET or Life NEXUS. It is worthwhile to notice that following the data from the end of previous decade in Switzerland alone the annual electricity generation from energy recovery in municipal water network was close to 85 GWh with a remaining potential of 224 GWh.

## **Irrigation Water Systems**

Irrigation water adductions can also be used to generate electricity as it is the case with the Armary hydropower plant in Switzerland (105 m, 68 kW). Low head applications, using Kaplan or bulb turbines, are also possible in irrigation channels, as in Petiva in Italy (6 m, 875 kW).

A comprehensive case study on the consideration of a hydropower plant associated to an existing irrigation system at the lower Awash basin in Ethiopia has been prepared as part of a Master thesis at the IHE Institute of Water Education in Delft (Tesgera, 2018). In this case the electrical energy can be extracted from an existing system without hindering its main function linked to food production, representing an added value for the owner, for the local population and for the environment. Although not being implemented yet, it is a very good example as various possible solutions to exploit the hidden hydro opportunity are outlined.

## **Desalination stations and other industrial systems**

The tradition of hydraulic energy recovery in European industrial installations stems also at least from the middle of the 20th century and is linked mainly with the thermal power and chemical industries. Thermal power plants – both conventional (e.g. coal or gas fired) and nuclear ones – generally require large amounts of water for cooling purposes. After leaving the cooling system the cooling water is discharged to the nearby reservoir or river which is a good opportunity to recover a part of the energy used for pumping the fresh water into the system. A typical example of energy recovery in the chemical industry is applying hydraulic turbines to extract energy from the gas scrubbing process. Dedicated units have been offered for years by Sulzer (Franzke, 1970 and Sulzer, 2020). Biogas scrubbing offers new opportunities in addition to the traditional applications in fertilizer factories (Bansal and Marshall, 2010).

Desalination plants provide another opportunity in countries in necessity to use this technology due to fresh water deficits in ever wider extent. The technological process requires always huge amounts of energy. In case it is based on the osmosis phenomenon, depressurising the remnant salt concentrate provides an obvious opportunity for hydraulic energy recovery (Choulot, Denis, and Punys, 2012 and Huang et al., 2020). Of course, highly corrosive aggressiveness of the medium is one of technological disadvantages, which is however solved by appropriate choice of material (duplex steels).

It is important to mention that the turbines installed in cooling systems or in desalination plant are recovering energy only, as the water has been pumped before being turbined. There is no electricity production, but a reduction of the electricity consumption of the pumps. In the case of drinking, irrigation and wastewater turbinning, there is a real electricity production, as the pressure is given by the difference in elevation between the inlet and the outlet as it is the case in any classical hydropower scheme.

## **Residual flow outlets in existing dams and weirs**

Using residual flow outlets at existing dams and weirs is rather an old, but still attractive opportunity to recover otherwise dissipated energy by means of traditional small hydro technology. When the released flow is nearly constant, pumps in turbine mode of operation can be a reasonable choice. However, environmental regulation is more and more requesting variable residual flow, depending, among others, on the season. In that case, Pelton, Francis or Kaplan turbines are needed.

Minimising the loss of hydropower potential in fish passage systems is possible by regulating the discharge according to the fish migration seasons whereas partial recovery of energy used for driving the so called active fish ladders (lifts) is effected in the Archimedes double-screw systems (see section 3.1.5).

## **Navigation lock gate bypass conduits**

Recovery of hydraulic energy lost when raising or lowering water level in navigation lock chambers is an opportunity ever more realistic in view of advent of variable speed technology allowing running hydraulic units with

reasonable efficiency at highly variable head (Zhang et al., 2018). The opportunity can be considered especially attractive in case of new infrastructure linked with development of new or restoring old inland navigation routes.

### 1.3.2.2 Upgrading of inefficient/abandoned SHP-Plants

The second group of hidden hydro encompasses already harnessed sites with hydraulic energy getting lost due to

1. unsatisfactory performance characteristics of hydraulic units installed including discharge spilled at existing installations due to obsolete technology/design or some other technical reasons;
2. non-optimised operation of units (especially double-regulated), multi-unit hydropower plants, or power plant groups (especially river cascades).

Rehabilitation and upgrading, including replacement of turbine components or whole units, is always an option to be considered in the first case and the European industry can offer expertise and technical solutions necessary for solving technical problems.

While optimizing double-regulated turbine cam curves can be considered a routine activity, optimized operation of multi-unit power plant and plant group is by far not a simple task, usually solved using contemporary software. Hydropower digitalization is fairly advanced in numerous European companies and the relevant software can be adopted for users worldwide.

### 1.3.3 Fish friendly Innovative Technologies for Hydropower

With its efficiency, relatively low costs, technical maturity and low CO<sub>2</sub> footprint as well as its reliability and predictability, hydropower maintains a prominent position amongst renewables in the European Union. The potential for hydropower development in the EU is extensive, especially considering that many existing hydropower plants will need to undergo refurbishment and upgrading in the coming years to conform to the environmental objectives of EU legislations, such as the EU Water Framework Directive.

FIThydro, Fishfriendly Innovative Technologies for Hydropower, is a 4-year EU Horizon2020 research and innovation action with 26 partners (13 research, 13 industry) from 10 European countries, involving several of the leading companies in the renewable and hydropower energy sector in Europe. The project's aim is to test and develop cost-effective environmental solutions, strategies and measures to ensure self-sustained fish populations and increase the ecological compatibility of existing and new hydropower schemes.

Special emphasis is placed on the application and enhancement of technologies, methods, tools, and devices at 17 test cases across Europe. These test cases were chosen to represent some of the main challenges facing hydropower development in four regions across Europe, namely Scandinavia, the Alpine region, France and Belgium for Northwest Europe, and the Iberian Peninsula. Scenario modelling in different geographic, climatic, and topographic test case regions will allow the quantification of effects and resulting costs for different mitigation options in Europe.

The key outputs from the project are two-fold: 1) A set of novel risk assessment and decision making tools to help practitioners evaluate, plan and find solutions for fish-friendly hydropower, and 2) a number of innovative and improved methods, tools and devices to address key challenges related to the assessment of self-sustained fish populations and fish-friendly hydropower production.

The investigations for new and improved solutions centre around four relevant impact areas: upstream migration, downstream migration, habitats and flow, and sediments. As a first step, an extensive review of existing methods, tools and devices and their application range was conducted (see Dewitte, 2018). A selection of suitable tools was then applied, tested, enhanced and developed at test cases and in laboratories across Europe (see Dewitte and Laurent, 2019). These include devices to improve the assessment of fish behaviour at hydropower

plants, fish guidance and protection systems, assessment methods for upstream and downstream migration facilities as well as tools for the assessment of impacts from hydro-peaking.

### **Innovative and improved methods, tools and devices**

Barriers such as dams and weirs pose a major obstruction to migrating fish. Fishways are the most common way to bypass the barrier and enable (upstream) fish migration and many have been installed at hydropower plants in Europe. However, their actual effectiveness is often unknown. To address this, the findability of the fishway entrance and fish swimming behaviour during upstream migration is studied at several FIThydro test case sites. Sufficient “attraction flow” from the fishway is seen as one of the important stimuli for fish to find the fishway entrance. For a more accurate assessment of how fish perceive this flow and consequently increase its effectiveness, the iRon Lateral Line Probe has been developed. It mimics the lateral line sensory system used by fish in nature and is the world’s first lab- and field ready instrument to capture ‘flow from a fish’s perspective’.

Another important aspect for effective upstream migration is the downstream migration habitat, which can influence fish swimming behaviour. The CASiMiR-Migration software was developed further with input from test case results to model fish swimming path during upstream migration by mimicking fish behaviour. Additionally, the software is used to model migration corridors for different flow rates, enabling an assessment and potential improvement of the available habitats for upstream migration. These new tools can support the planning of new and assessment of existing solutions for upstream migration, such as the construction of fishways.

While solutions for upstream migration have been extensively studied over the last decades, there is a lack of solutions and design standards for downstream migration. FIThydro addresses this issue in several ways. Fish guidance and protection structures are often installed in the headwaters to reduce fish injury and mortality, but effective fish protection settings can also cause increased head losses and more turbulent turbine admission flows. The newly developed Curved-Bar Racks (CBR) are mechanical behavioural fish protection and guidance structures that provide both, high fish protection and guidance efficiency as well as a significantly improved hydraulic performance. The CBRs are suitable for medium to large hydropower plants with high design discharges ( $Q > 100 \text{ m}^3/\text{s}$ ) and high approach flow velocities and could be an alternative to fine-screened horizontal bar racks for small hydropower plants (Beck, 2019).

In many cases, the only way for downstream migration of fish is to pass through the turbines. The Induced Drift Application is a protection system that is installed directly in front of the turbine and increases the survival probability of fish during turbine passage by a factor of two. This is done by guiding and immobilizing fish before the turbine runner passage. It provides an effective and cost-efficient way to improve the survival rate of fish during turbine passage and is especially applicable for retrofitting of existing large-scale run-of-river hydropower plants.

To quantify the hydraulic conditions during downstream turbine passage, which can lead to pressure induced mortality, and to gain accurate measurements, the Barotrauma Detection System (BDS) was developed and applied at several test sites. The BDS passes the turbine the same way that fish do and collects information on the pressure and inertial changes that fish experience. The recorded data allows the assessment of impacts from turbine passage and can be used to identify where turbine passage is acceptable. Furthermore, the BioPA fish passage model developed in the US, was adapted to European conditions resulting in best practice guidelines for the application of turbine fish mortality modelling using BioPA (see Stoltz and Geiger, 2019). The turbine hazard modelling enables a case specific adaptation of turbine operation modes during fish migration periods.

Next to impacts and mitigation measures for fish migration, the availability and use of habitats is studied at several test sites. This ranges from the creation of additional spawning and rearing habitats in fishways to studying the impacts of hydropeaking on fish behaviour and habitat availability. The CASiMiR-Hydropeaking software is used to simulate impacts of hydropeaking on downstream habitat availability, allowing an adaptation of hydropower operation and development of mitigation measures. Additionally, the Hydropeaking Impact Assessment tool extended to Iberian cyprinids, enables the assessment of direct effects from hydropeaking as well as of the

vulnerability of fish species to hydropeaking. By assessing existing or planned hydropeaking, possible risks and mitigation measures can be identified.

### **Novel risk assessment and decision making tools**

To support the risk assessment and decision making process of operators, engineers and authorities, FITHydro also developed a number of risk assessment and decision making tools. The Fish Population Hazard Index is the first European-wide guidance and assessment tool for fish hazards in hydropower environments (Wolter, 2019). It is an environmental impact assessment tool for existing and planned hydropower plants that supports the implementation for sustaining and improving local fish populations. To assess the impacts of several consecutive hydropower plants and dams in a single river basin and evaluate the population response to different mitigation measures applied, FITHydro also developed the Cumulative Impact Assessment tool (Cowx, 2020).

The more comprehensive Decision Support System (DSS) allows an assessment of risks to fish populations in hydropower affected rivers and helps the user to select appropriate mitigation measures. The DSS considers the specific hydropower plant characteristics, national environmental status assessments as well as environmental and conservation policies and mitigation requirements. Information on possible mitigation measures as well as a description of the methods, tools and devices can be found in the FITHydro wiki.

The FITHydro outputs support managers, engineers, ecologists and hydropower operators in the assessment, planning, commissioning and operation of ecological compatible and fish-friendly hydropower schemes. They are of relevance for the planning of mitigation measures for specific hydropower plants as well as for broader processes such as river basin management planning under the WFD. The results and tools are accessible via the FITHydro website where more information on the project can also be found.

### **Acknowledgement**

The work and the ideas described here are the product of contributions of many people from the 26 partners in FITHydro. This project received funding from the European Union's Horizon 2020 research and innovation programme under grant agreement no. 727830.

## 2 Small Hydropower Systems

### 2.1 Low head or high head

The hydropower plant head and discharge are key parameters of any existing or planned hydroelectric installation. The plant head is the difference of liquid mechanical energy per unit weight as measured at plant inlet and outlet. For classification purposes it is usually enough to identify it with its gross value defined by the difference of the upper and tail water levels. This simplified approach may appear insufficient when high accuracy is required or a hydraulic energy recovery installation with no free liquid surface available at either side is considered. In such cases the plant head should be calculated from the formula  $H = E/\bar{g}$  with

$$E = \frac{p_{abs1} - p_{abs2}}{\bar{\rho}} + \frac{v_1^2 - v_2^2}{2} + \bar{g}(z_1 - z_2)$$

representing the specific hydraulic energy related to the unit mass of liquid, and  $p_{abs}$ ,  $v$  and  $z$  standing for absolute pressure, average flow velocity and elevation taken at the inlet and outlet installation reference sections 1 and 2, respectively (IEC 60041, 1991). In case of high head installations some differences between liquid density and acceleration of gravity,  $\rho$  and  $g$  may occur and therefore mean values have to be used.

The division between high, medium and low head installations is a matter of stipulation. Traditionally, hydropower installations with head above 70 m have been considered high head plants and those with head below 30 m – low head ones. More modern classification rules use the 50 and 15 m thresholds, respectively. In addition, in case of small hydropower installations, the terms of very low head (< 5 m) or ultra low head (< 2.5 m) are occasionally used.

There are multi-aspect reasons for such categorization. Those related to mechanical engineering aspects follow from differences in the type of hydraulic turbines and other hydropower engines applied in the consecutive head intervals. Figure 2 illustrates such a division for a wide range of turbines as offered by the Escher Wyss company (nowadays Andritz Hydro). Typical application range limits for small hydro turbines are shown with dashed lines. The diagram should be considered only an indicative one. Especially in the small hydro area where the limits are much more manufacturer dependent (e.g. for small hydro it is common to have Pelton turbines for heads below 100 m). The net head used to characterize hydraulic turbines is lower than the gross one as used to characterize the hydropower installation. The reason lies in situation of reference sections and levels which have to be taken at the turbine inlet and outlet in the first case. In particular, the lower reference section of reactive turbines is taken at the draft tube outlet whereas turbine runner axis or its lowest edge elevation are used in case of impulse turbines. In case of low head installations the difference may be linked in greater extent with kinetic energy loss at the draft tube outlet whereas hydraulic losses in the penstock may be of key significance in case of the high head units. Hydraulic energy is always related to the lower reference level and therefore the word-ing “energy difference” is generally omitted in relevant considerations.

The use of specific hydraulic energy and other related terms is often preferred by modern standards as they address directly the physical nature of the energy conversion process. Furthermore, they allow also getting free of the acceleration of gravity impact on the turbine performance parameters when reporting the performance test results which usually include determining the turbine or unit efficiency from a rather obvious ratio

$$\eta = \frac{P}{\rho Q E}$$

with  $Q$  and  $P$  denoting respectively the discharge and usable power defined according to the needs and/or stipulations. Due to tradition and obvious practical reasons, the head parameter is in much wider use than the specific hydraulic energy, especially in case of small hydro, for which guarantee requirements are formulated in a much softer way than those related to the large hydro equipment.

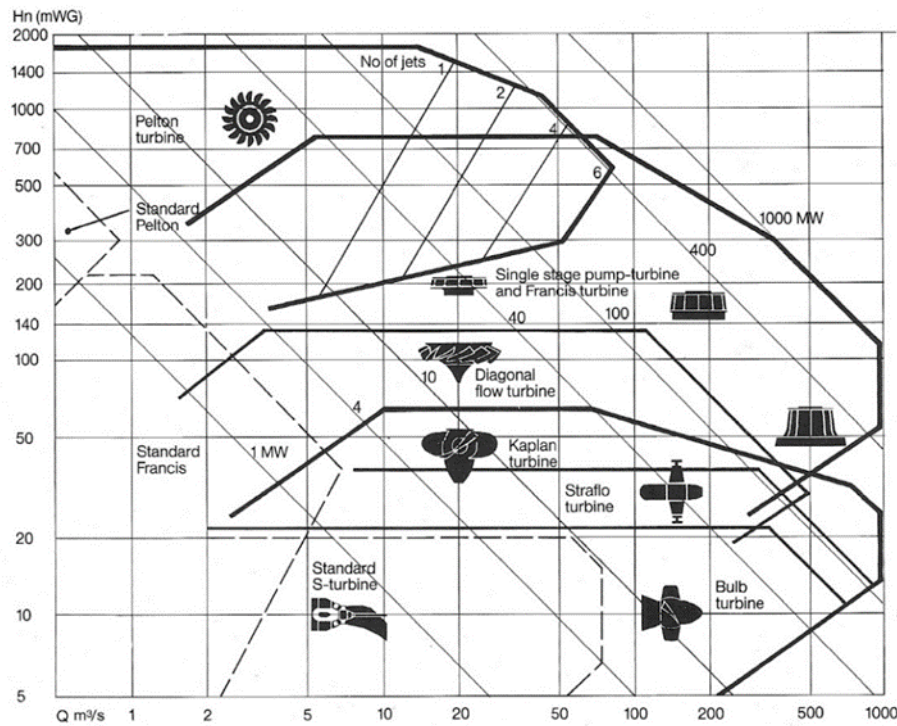

**Figure 2: Application range of various kinds of hydraulic turbines as offered by Escher Wyss, now Andritz Hydro (Raabe, 1985)**

The situation with hydrokinetic turbines is different and resembles that of wind turbines. The specific energy parameter is to be replaced by that of raw power density  $\varepsilon$  [W/m<sup>2</sup>] or power flux  $P$  [W] passing the turbine rotor (runner) swept area and calculated as

$$\varepsilon = 0.5\rho V_{\infty}^3 \text{ and } P = \varepsilon A$$

With  $\rho$  denoting the water density and  $V_{\infty}$  – its undisturbed flow velocity. The hydraulic efficiency parameter is replaced by that of power coefficient which represents the ratio of useable power extracted from a stream of fluid passing the turbine rotor (runner) swept area  $A$  to the raw kinetic energy flux  $P = \varepsilon A$  of this stream. Following the Betz law, the turbine power coefficient is limited to the theoretical value of  $16/27 \approx 59.3\%$ . The limitation follows mainly from the flow continuity law. In case no additional measures – such as locating the runner in a nozzles or flumes - are undertaken in order to increase local flow velocity, the true power coefficient value is always smaller than that following from the Betz law. Further reduction can follow from the limited flow channel cross-section or parallel operation of several hydrokinetic units. Extracting a major portion of kinetic energy – especially in artificial canals – results in a damming effect and changing conditions downstream the installation according to the principles of free surface flow hydraulics.

All gravitational engines are low head units. Water pressure remains the same at the machine inlet and outlet. Potential energy of gravity between machine inlet and outlet is converted into useable work. Only in some cases (Zuppinger wheel) kinetic energy may also contribute to the process.

Generally, widening the range of hydropower applications both in terms of power and head, and especially decisive decreasing the lowest head limit – including commercializing hydrokinetic technology – is quite apparent over the passing decades. However, the progress affects not only the hydraulic machinery used in hydropower installations. An even more significant impact is exerted on civil engineering works discussed. In case of both high and low head installations European companies can offer enhanced dam erection and maintenance technologies, including high quality structural materials and new materials used especially for sealing purposes (e.g. geotextiles



applied at the dam upstream side) as well as dam safety monitoring systems. Successful implementation of fusegate technology (Chevalier, Culshaw, and Fauquez, 1996) for ensuring dam safety and the widening use of inflatable weirs for lowest head installations are also to be mentioned in this context.

## 2.2 In-stream or diversion installations

Hydropower plants classification can follow different criteria (Raabe, 1985 and Giesecke and Mosonyi, 1998). One of them is the powerhouse location respective the dam. In case of numerous installations, diversion scheme with water delivered to the turbine(s) via a pressurized diversion conduit (penstock and/or tunnel with concrete lining) is necessary in order to make use of the full gross head available.

Generally, diversion schemes allow to convert hydraulic energy into electricity far away from the water abstraction site. The great advantage is possibility to use relatively low weir in order to achieve high or very high gross head. In case of some small high head installations erection of any major weir can be avoided as water intake is located directly in river sill or at the weir downstream side (drop-in intakes).

Old riverbed in diversion schemes can be generally used as a natural bi-directional fish pass although one has to count with very high residual flow necessary in mountainous regions. However, diversion schemes are applied also at relatively low heads, allowing to use hydropower potential in case of moderate river bed slopes while avoiding extensive flooding and infrastructure costs. The typical diversion scheme starts with a weir dividing the flow between the old river bed and the diversion conduit which – depending on local topography – remains often unpressurised in its upper part (water supply canal) and ends with water intake forebay. The size and length of both unpressurised and pressurized diversion portions follow from optimization aimed at attaining high head with low hydraulic losses and still reasonable erection costs. The pressurized conduits are often furnished with surge towers in order to avoid excessive water hammer accompanying transient states of operation (see section 3.6.3). A typical example of such a hydropower scheme is shown schematically in Figure 3.

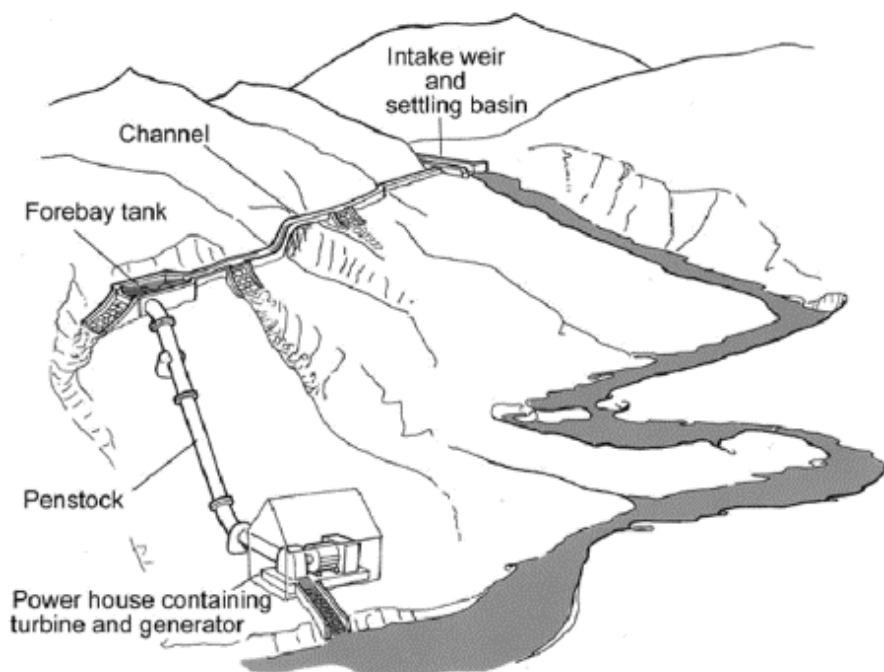

**Figure 3:** Schematic of a small hydro diversion scheme (Gatte and Kadhim, 2012)

In case of some low head installations only non-pressurised short diversion canals are used with the task to bypass the main water course and deliver water to the intake located in direct neighbourhood of the existing dam

or weir (Figure 4 and Figure 5). Erecting a power plant at an originally dry land has its obvious advantages, especially if damming by the already existing weir is to be used. In case of a very short diversion the configuration is very close to that of a river bay hydropower installation (Giesecke and Mosonyi, 1998).

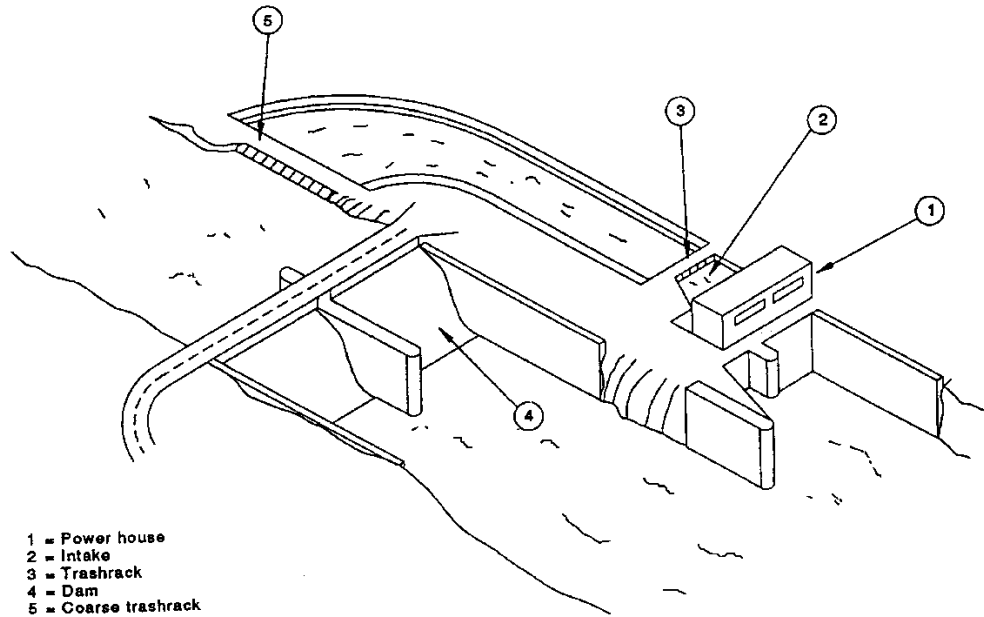

Figure 4: Run-of-river hydropower plant with a short diversion canal (EN 61116, 1992)



Figure 5: Malczyce SHP (9 MW) - Oder river, Poland (Wody Polskie, 2020)

The in-stream power plants can be incorporated into the dam structure (Figure 5) or located at the dam basis on its downstream side. The typical in-stream hydropower plant configuration can be classified into several categories according to powerhouse situation respective the dam or weir (Giesecke & Mosonyi, 1998):

1. block configuration with powerhouse located in one block at one riverside;
2. twin configuration with powerhouses at two sides of the river;
3. distributed configuration with hydraulic units located in dam segments between the pillars.

In case using a part of the dam for the powerhouse purposes could create problems for conducting the flood waters or river navigation some special configurations such as

4. bay configuration with power plant located in a river bay excavated at one riverside
5. overflown (submerged) power plant located beneath the overflow spillway or even below the weir stilling basin

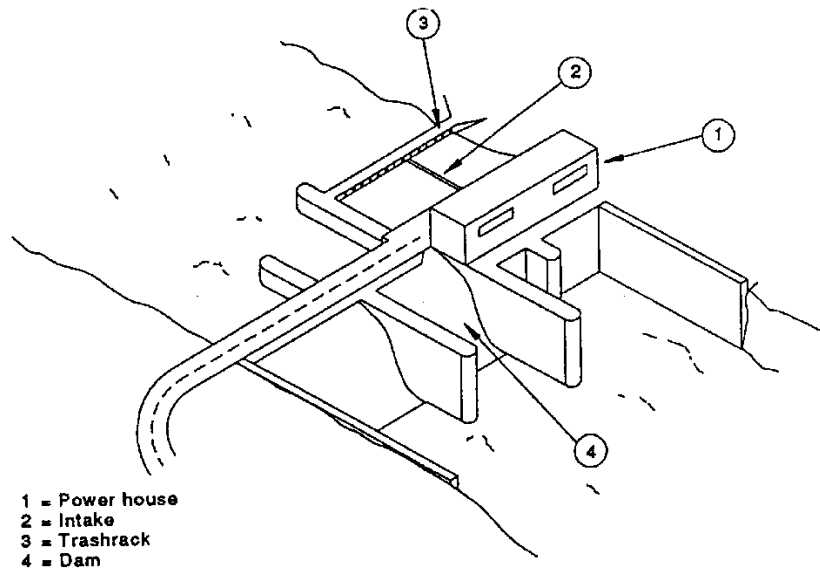

**Figure 6:** In-stream run-of-river SHP located at the left riverside (EN 61116, 1992)

In most cases of low head in-stream or short non-pressurised diversion schemes, it is essential to make sure of adequate flow pattern at the power plant inlet. Improper flow pattern can result in increased forebay hydraulic losses, fall of power capacity and generation. Different capacity of neighbouring units running at the same gross head is a typical result. The most reliable optimisation is generally conducted basing laboratory model tests supported by CFD calculation. Figure 7 shows resulting shaping of the inlet canal cross-section in a low head power plant at Oder river in Poland. The purpose is to attain equal discharge through two neighbouring pit turbine units.



**Figure 7: Shaping the inlet canal of Januszkowice SHP (1.5 MW) - Oder river, Poland**  
(source: IMP PAN archives)

There is a continuous progress observed in planning and technology used for erecting diversion and in-stream power plants. Increased capacities available for tunnel drilling and new lining technologies should be mentioned in case of medium and high head installation. High experience in surveying potential new SHP sites and developing low head power plants using damming by means of the already existing weirs are also important aspects of the progress.

### 2.3 Run-of-river or storage

The terms used in the heading of this subsection may seem self-explanatory. However, due to storage capacity being always more or less limited, it is worthwhile to remind the classification proposed in the 1990s by *Unipede-Eurelectric* (Punys, Dumbrasukas, Kasiulis, Vyčienė, Šilinis, 2015). The classification uses time  $D$ , the annual average inflow needs to raise water level in the forebay by the power generation designated layer. Following this approach the power plants with a  $D$  parameter smaller than two hours are generally considered the run-of-river ones.

The run-of-river schemes are furnished with no reservoir at all or only a small one. If not in a cascade, they are incapable to fulfil any regulation functions. In numerous countries run-of-river installations dominate in the small hydro sector. It is always important that their discharge capacity range is wide enough. If in a compact cascade, they can consist a component of a regulating system supporting both water management and electrical grid needs.

The hydropower schemes featured by a higher  $D$  parameter are often merged into the same group with reservoirs classified as those with daily, weekly or seasonal levelling duration. It should be emphasized at this place that storage in case of a hydroelectric installation implies always storage of both water and mechanical energy which can be converted into electricity at any suitable time. This notice is of importance as in numerous cases storage hydropower plants are just components of major multipurpose projects and their erection cost may represent only a small portion of that of the upper water reservoir, constructed mainly for the purposes of water retention, irrigation and/or flood protection. In view of the ongoing climate change such public or public/private investment schemes are of rising significance. Hydropower plants located at reservoirs built mainly for water

retention and irrigation purposes are often small installations, capable for a regulatory role in a local grid, e.g. isolated and/or a smart one.

Erecting larger storage plants generally requires also a tailwater reservoir, usually furnished with another hydro-power plant responsible for alimentation of the downstream river reach. Further increasing regulating capacities is possible also by erecting a cascade. In case the cascade is to be operated in the so-called swell regime only the last stage should be furnished with a reservoir of capacity enabling regular outflow irrespective of discharge at the upper stages. The intermediate stages should show discharge and storage capacity allowing only to avoid the unwanted water level fluctuations in course of swell operation. If the cascade is compact enough, large capacity variations are possible with scarce impact on the water level at intermediate stages.

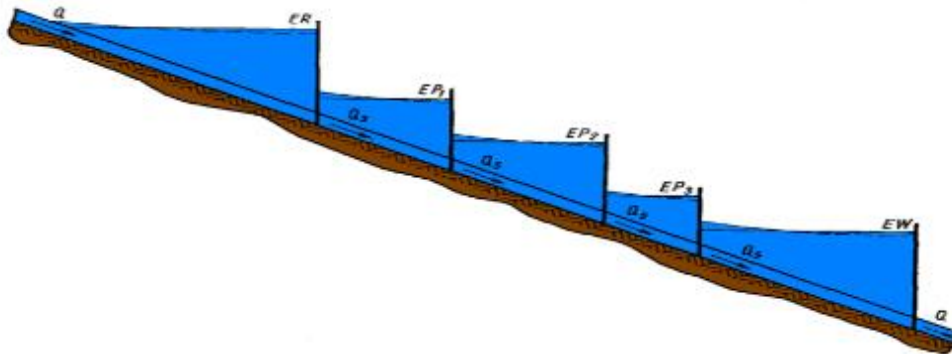

**Figure 8: Schematic of a compact river cascade capable for swell operation without major water level variations at the intermediate stages (Michałowski and Plutecki, 1975)**

The scheme incorporating upper and lower reservoir can be used also for pumped storage purposes. The ever rising use of intermittent electricity sources results in growing demand for regulatory services covering not only peak load operation, but also compensation of electricity supply fluctuation, including absorption of energy surplus in the grid and its storage. The demand for such services concerns not only the national grid which requires large projects, but also local ones. In case of small isolated grids, combining solar and/or wind based electricity sources with small storage or pumped storage hydroelectric schemes may be just the most appropriate solution. They can be also considered a component of a hybrid power plant with one grid connection point for various electricity sources.

The investment costs of small pumped-storage installations can be sometimes lowered by using two hydraulic machines (pump and turbine) instead of a dedicated pump-turbine. Various configurations are possible, including those of a hydraulic short-circuit with a triple machine unit (Figure 9). Small capacity pumped storage has gained substantial interest in Europe since the beginning of this century and therefore there exists already substantial know-how in this respect.

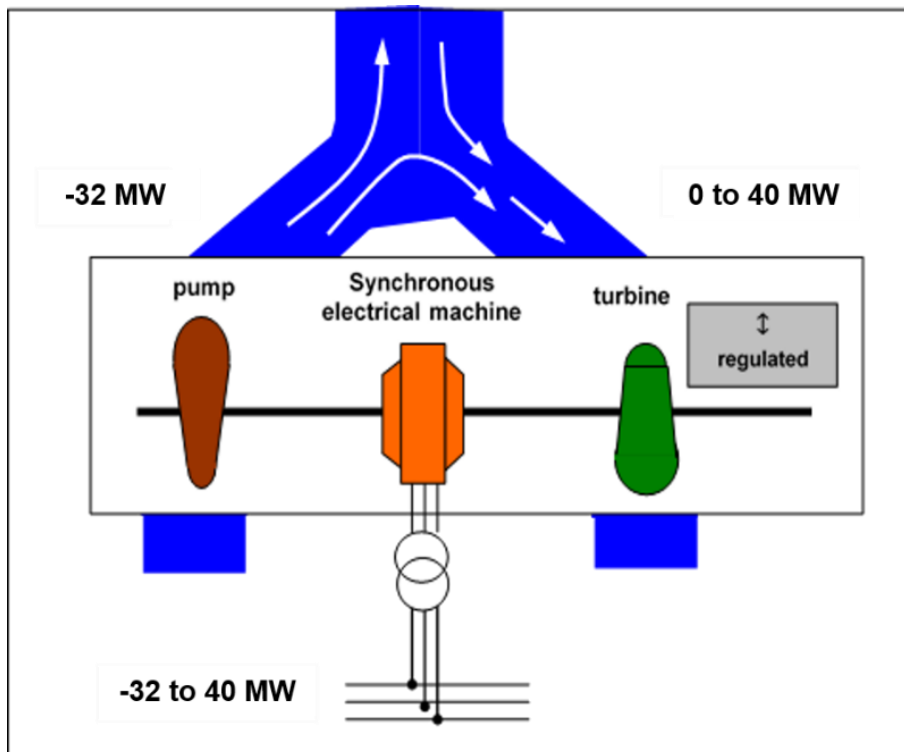

Figure 9: Schematic of a triple machine unit run in a hydraulic short-circuit system in Geesthacht PSPP (Germany). The same system can be replicated in a smaller scale (Bellmann, Sebestyen, and Wührer, 1999)

## 3 Overview of Hydropower System Components

### 3.1 Hydraulic turbines and gravitational hydropower machines

#### 3.1.1 Introductory notes

Turbines are generally divided into impulse and reaction ones with reactivity degree defined as the ratio between the runner inlet/outlet pressure difference height and the net head. Typical examples of impulse turbines are Pelton and Turgo turbines featured by equal static pressure at the turbine runner inlet and outlet. Kinetic energy of water jet(s) leaving the turbine nozzle(s) is converted here in the useful kinetic energy of the hydraulic unit rotating assembly. In case of classic reactive turbines (Francis, Deriaz, Kaplan and other axial-flow ones) the pressure difference height is generally comparable with head. The degree of reactivity can be increased by applying draft tubes which increase turbine discharge and efficiency as referred to the gross head by lowering the static pressure downstream the turbine runner. This is of especially high significance in case of classic low head turbines.

The hydraulic turbine principle of operation is based on exchange of angular momentum between the onflowing water and the runner which is expressed quantitatively by the basic equation of turbines, known also as Euler equation. Gravitational water engines, such as Archimedes screw or Steffturbine™ hydraulic units, are sometimes called water turbines as well although they are hydrostatic machines, put in motion by the weight of water filling the buckets. The high significance of Archimedes screw based hydroelectric units in small hydro applications follows from various reasons which will be discussed in subsection 3.1.5.

#### Performance factors and characteristics

Turbine size and rotation speed selection for a specific application is generally based on similarity laws following from assumption of full geometrical and kinematic similarity of the flow systems. The resulting similarity factors have been written down following the nomenclature and symbol designation of the IEC 60193 (2018) model test standard (Table 2). Slightly modified factor definitions are to be used in case of cross-flow turbines which discharge is proportional to the runner width  $B$  by diameter  $D$  product and not the  $D^2$  value.

**Table 2: Non-dimensional and dimensional performance parameter factors (IEC 60193, 2018)**

similarity factor	non-dimensional	dimensional
rotation speed factor	$n_{ED} = nD/E^{0.5}$	$n_{HD} = nD/H^{0.5}$
discharge factor	$Q_{ED} = Q/D^2E^{0.5}$	$Q_{HD} = Q/D^2H^{0.5}$
torque factor	$T_{ED} = T/\rho D^3E$	$T_{HD} = T/D^3H$
power factor	$P_{ED} = P/\rho D^2E^{1.5}$	$P_{HD} = P/D^2H^{1.5}$

The mentioned similarity factors represent values the respective quantities would take in a similar flow system with unit reference diameter  $D$  [m], operating at unit specific energy  $E$  [J/kg] or net head  $H$  [m], respectively. Due to this reason the 11 subscripts are used instead of HD in some traditional national nomenclatures to describe the dimensional factors. It is to be mentioned that a consistent system of units with rotation speed  $n$ , discharge  $Q$ , torque  $T$  and power capacity  $P$  expressed in 1/s, m<sup>3</sup>/s, Nm and W, respectively, is used to derive the non-dimensional factors. Angular velocity factor is also used sometimes instead of the rotational speed one. The dimensional factors are usually derived using the same quantities expressed in rpm, m<sup>3</sup>/s, kGm and kW units. In practice, the reference diameter and head values are often introduced into the formulae without units when

calculating the dimensional factors. Eventually, all the dimensional factors are expressed in the original physical units.

Despite some inaccuracies - mainly due to viscosity related scaling effects, quite apparent far from the best efficiency point of operation (bep) - the similarity laws are of paramount significance when conducting model tests and using their results for planning new hydropower plants. In fact, the basic performance characteristics including the efficiency hill chart (Figure 10) as well as the four-quadrant discharge and torque characteristics are usually plotted in the coordinate systems defined by the abovementioned dimensional or non-dimensional factors.

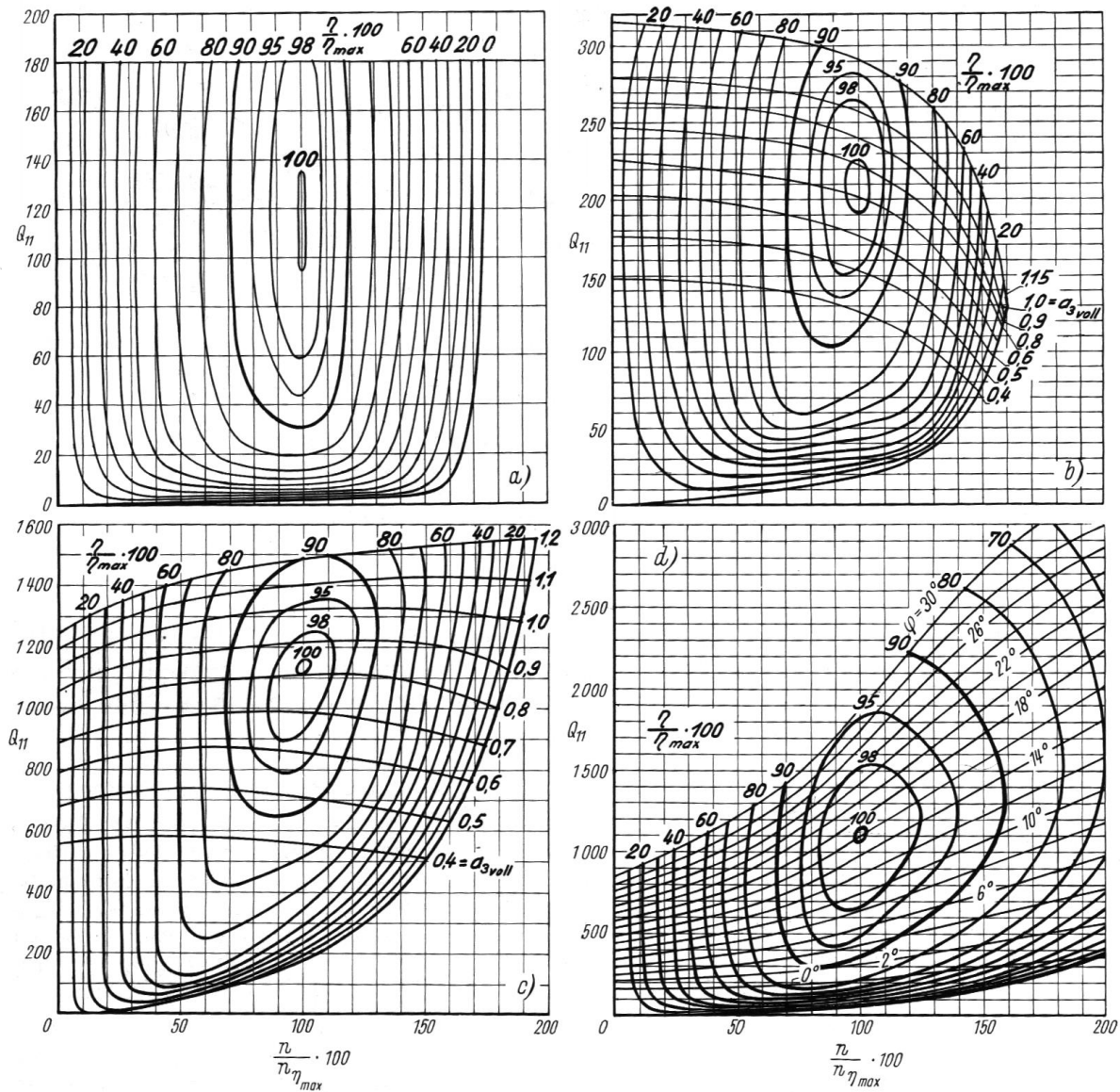

Figure 10: Normalised efficiency hill charts in the  $(n_{HD}/n_{HD, opt}, Q_{HD})$  plane for a Pelton turbine (a), low and high specific speed Francis turbine (b and c, respectively) and a Kaplan turbine (d). (Raabe, 1989)

Normalisation concerns rotation speed and efficiency. The discharge factor is expressed in l/s. Francis turbine wicket gate openings are shown as fractions of the full opening value.



### Specific speed and tip speed ratio

Hydraulic similarity considerations have lead also to introducing the term of kinematic specific speed which is defined as the rotation speed of a hydraulic turbine of unit reference diameter running under unit head or specific energy with unit discharge and showing full geometric and kinematic similarity of its flow system to the one of the turbine under consideration. The respective non-dimensional and dimensional formulae are as follows

$$n_Q = n Q^{0.5} / E^{0.75} = n_{ED} Q_{ED}^{0.5} \quad \text{and} \quad n_{sQ} = n Q^{0.5} / H^{0.75} = n_{HD} Q_{HD}^{0.5}$$

There is some ambiguity in these definitions as performance parameters used may refer either to the best efficiency or to the rated operation point. This may be of significance in case of Kaplan turbines, for which the discharge at the best efficiency point constitutes often only 3/5 of the rated value. An angular velocity based "scientific" definition of the specific speed is widely used in the French hydropower engineering literature.

In the past, the so called dynamic specific speed representing rotation speed of a hydraulic turbine of unit reference diameter running under unit head and providing unit power output was often in use. The relevant definition formula is

$$n_{sP} = n P^{0.5} / H^{1.25}$$

with the power output value  $P$  expressed usually in HP (horsepower) units. Some ambiguity in the relationship between the  $n_{sP}$  and  $n_{sQ}$  parameters follows from the need to assume the turbine efficiency value. The approximate practical relationship is  $n_{sP} = 3.65 n_{sQ}$ .

The specific speed is called also the runner shape or turbine type number as it is directly linked with the optimum turbine type and runner geometry (Figure 11). High specific speed designs are both economically and technically advantageous as they allow reaching high discharge capacity and power output by units of relatively small size. This is of especially high significance in case of low head units operating in shallow waters and requiring high discharge factors in order to avoid unacceptably large runner diameters and excessive installation costs.

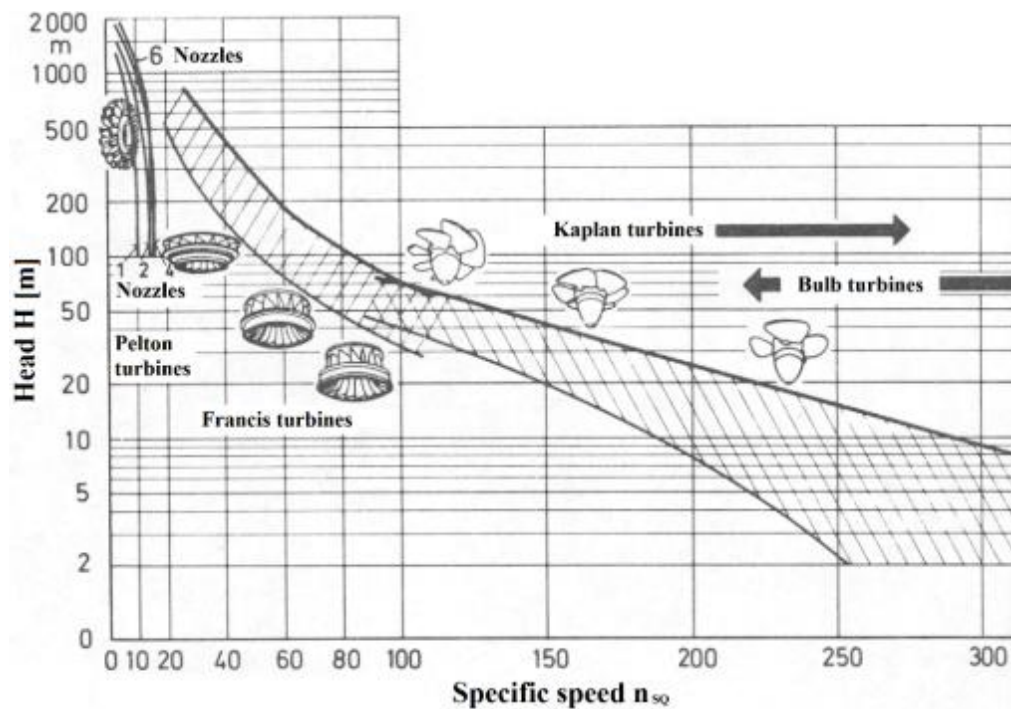

Figure 11: Classic turbine types as dependent on the specific speed parameter (Raabe, 1989, after Voith)

The physical interpretation of the discharge factor  $Q_{HD}$  definition is directly linked with famous Torricelli formula and shows proportionality between the average axial velocity  $V_{ax}$  and the head root  $H^{0.5}$  which can be written down as  $V_{ax} \propto Q_{HD} H^{0.5}$ . This observation allows to notice that the specific speed coefficient  $n_{sQ}$  is directly proportional to the expression

$$\frac{\omega D}{2V_{ax}} Q_{HD}^{1.5}$$

with  $\omega$  [rad/s] denoting the angular velocity of the runner. In case of hydrokinetic turbines the coefficient

$$TSR = 0.5 \omega D / V_{ax}$$

with  $V_{ax} = V_{\infty}$  standing for velocity of the undisturbed flow, is called the tip speed ratio as it represents the ratio between runner peripheral velocity and that of the undisturbed flow. The  $TSR$  parameter cannot be called a shape number. Nevertheless, Figure 11 shows that it is possible to correlate the  $TSR$  value with the recommended hydrokinetic turbine type and its power coefficient. The diagram is based on the wind turbine literature (Menet, 2004, and Wilson and Lissaman, 1974) and shows power coefficients of various wind turbine rotor types including those of historical Dutch and traditional American windmills, 2- and 3-bladed airscrews, and two cross-flow ones, meant here as those featured by fluid stream entering and leaving the rotor space in direction perpendicular to the shaft axis. As the aerodynamic machines and their components have been often used to study performance of the hydrodynamic ones, the modified Wilson and Lissaman diagram is still widely used to explain differences in performance of various hydrokinetic turbine types.

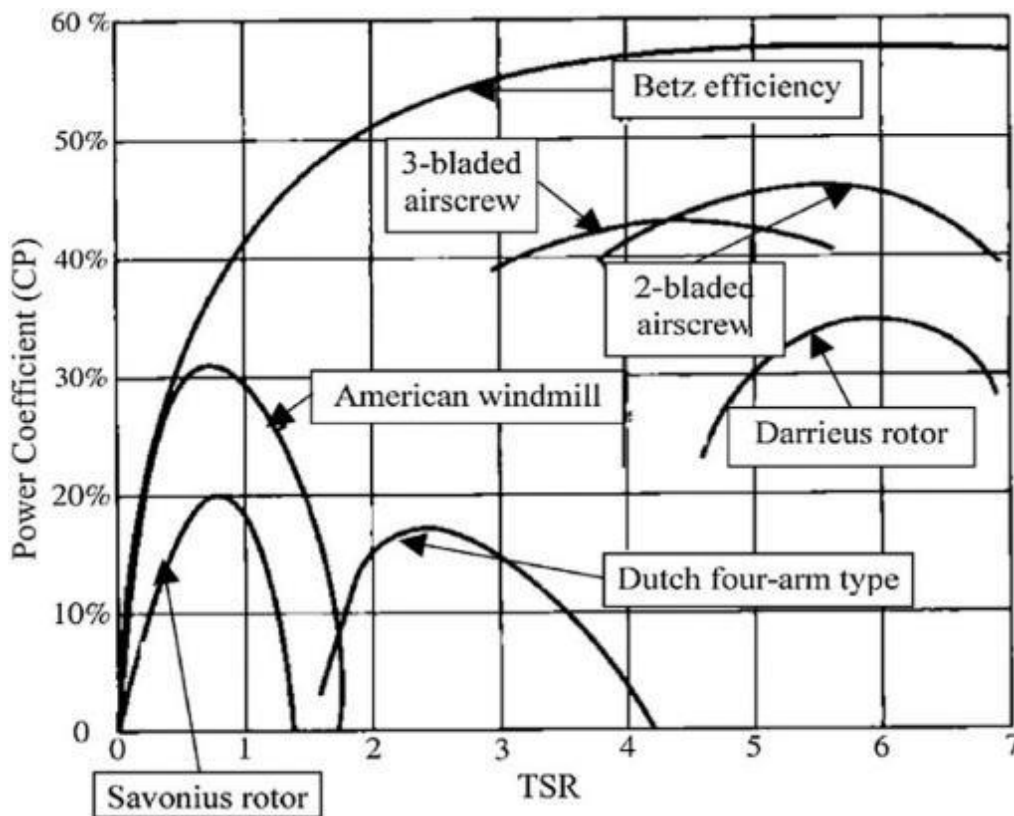

Figure 12: Typical parameters of wind power rotors (Saini and Saini, 2019 after Menet, 2004, and Wilson & Lissaman, 1974)

### Cavitation and slurry erosion

An increase in the specific speed value above that shown in Figure 11 is generally limited by cavitation phenomena which are unavoidable in case of high local velocities, also those due to presence of unsteady whirl structures, responsible for occurrence of deep depression areas and cavitation. Cavitation is a result of lowering the liquid static pressure below certain critical value (close to the saturated vapour pressure) which leads to an explosive growth of microscopic vapour/gas bubbles (cavitation nuclei) as it comes to breaking the quasi-static equilibrium between the ambient liquid pressure and bubble surface tension on the one side and the vapour/gas mixture pressure inside the bubbles on the other side. The same result achieved by increasing the vapour pressure due to heat transfer is generally known as boiling. Of course, both are different from the steady bubble growth which usually precedes the phenomenon and may be partially due to the dissolved gas diffusion through the bubble surface.

In fluid-flow systems the liquid depression areas are limited and it is possible that bubbles merge before leaving them, forming major fluctuating cavitation structures, often attached to the solid surface. Increasing vapour content in the working medium and development of major cavitation structures can substantially affect the whole flow field and turbine performance. However, from the viewpoint of hydraulic machine structural integrity, even more important are phenomena taking place when performance fall is still scarcely noticeable.

The collapse of cavitation bubbles and other cavitation structures due to their transfer into the areas of increased pressure or to pressure fluctuation shows an implosive character and results in a number of detrimental dynamic effects, including noise, turbine structure and shaft vibration, erosive damage to the flow confining surfaces. High aggressiveness of the phenomenon follows from sudden deceleration of liquid surrounding the collapsing bubbles which gives rise to high amplitude pressure waves. If the collapse is affected by a solid wall presence, emergence of a cumulative microjet can be also expected. Eventually, the solid surface is hit with pressure pulses of amplitude reaching locally values as high as several GPa, fully capable to exert substantial erosive damage (Figure 13).



**Figure 13: Extensive cavitation damage at the suction side of a small Francis turbine runner (1970s, source: IMP PAN archives)**

Cavitation is affecting not only hydraulic machinery and equipment, but also such civil engineering structures as hydropower water intakes. Vortex cavitation developing in large hydraulic structures of non-optimised geometry can show really spectacular effects, including cavitation damage holes with depth measured in meters.

In this context it is to be noticed that cavitation is not the only wear mechanism endangering hydropower machinery. Slurry erosion due to gravel, sand and silt transported with flowing water presents a serious threat to structural integrity of numerous hydraulic machines and equipment, especially those operated in streams and rivers taking their origin in mountainous areas and/or featured by frequent flood water surges. Typical examples of vulnerable machinery components are Pelton turbine nozzle needles and runner buckets. The situation may get even worse in case silty water starts to cavitate as synergistic effects due to accelerated impact of solid particles onto the streamlined surface are quite probable. On the other hand, synergistic effects with electrochemical corrosion are probable in some industrial energy recovery systems. One should bear in mind that electrochemistry affects most cavitation erosion processes although its contribution may be dominated by the mechanical factors.

The key method to mitigate cavitation damage of hydraulic machinery and equipment is proper design of the flow system, usually supported by reliable CFD simulations and model tests. The use of such construction measures as anti-cavitation strips in Kaplan turbines is also to be mentioned in this context. Sometimes CFD simulation can be also helpful in lowering the slurry erosion risk. However, the key measure to mitigate slurry erosion is proper design of water intake and all accompanying arrangements so as to minimize solid particle transport into the turbine flow system.

Whenever cavitation and/or slurry erosion load are unavoidable, selection of highly resistant structural material is of paramount significance. As the required technological and mechanical strength properties may appear incompatible with increased erosion resistance requirements, protective coatings have to be used. In addition to some traditional and troublesome techniques the European companies have developed within the recent decades a number of innovative technologies such as spreading carbide coatings – e.g. by means of the HVOF technique - or “painting” the streamlined surfaces with elastic composites. Substantial progress concerns also the post-damage repair technology.

The vibro-acoustic cavitation effects can occur irrespectively of cavitation erosion and are particularly intense in reactive turbines run under the partial load conditions. Especially spectacular are highly unwanted effects of collapsing cavitating vortex ropes. In some cases they can lead to powerful water hammer in the draft tube and pressurized outlet conduit if any. The situation may appear quite dramatic in case of hydraulic resonance between the vortex rope and the pressurized tailrace.

A phenomenon resembling cavitation and occurring in case of pressure inside a penstock falling below the saturated vapour pressure level is liquid column separation. In fact, significant underpressure inside the penstock is linked with high risk of penstock collapse. On the other hand, the final phase of liquid column separation can lead to penstock bursting due sudden stopping of liquid masses closing the cavity from both sides.

The key quantity describing cavitation threat to a reactive hydraulic machine is the so called Net Positive Suction Head (*NPSH*) defined as

$$NPSH = \frac{p_{abs} - p_{va}}{\rho g} + \frac{v_2^2}{2g} - H_s$$

with  $p_{abs}$  and  $p_{va}$  denoting the ambient and saturated vapour pressure values,  $v_2$  - average liquid velocity at the turbine outlet (draft) tube outlet and  $H_s$  - suction head defined as the difference between the turbine reference level and the free surface tailwater level (Figure 14). If needed the suction head value should be increased by the height of hydraulic losses inside the outlet conduit. Due to its physical interpretation, the *NPSH* parameter is also called the anticavitation suction head surplus in some national nomenclatures. Further modification of the definition, including direct reference to the specific energy concept, is required in case the turbine is installed in a closed conduit, e.g. in a hydraulic energy recovery system, with no open tailwater reservoir.

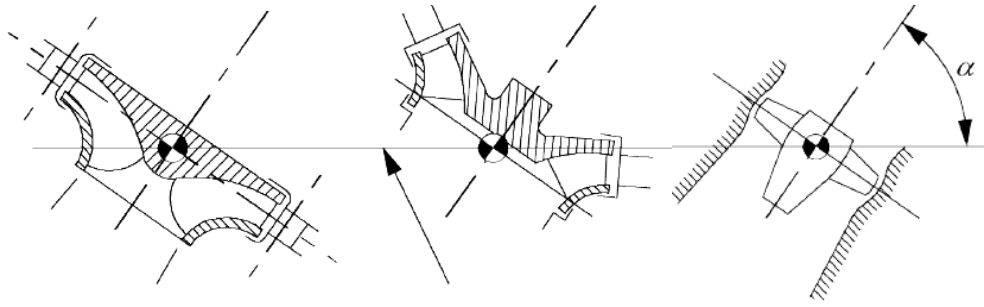

**Figure 14: Positioning of the reactive turbine reference levels. Arbitrary shaft axis orientation (IEC 60193, 2018)**

Establishing the allowable *NPSH* or suction head value basing on the laboratory model test results is possible by using the Thoma cavitation number

$$\sigma_{Th} = NPSH / H$$

which represents the key hydraulic turbine cavitation similarity parameter. Determining the allowable cavitation number under laboratory conditions is based on monitoring the rise of basic diagnostic signals, such as pressure fluctuation, vibration and acoustic emission supported by visual observation while lowering the Thoma number value and keeping the rotation speed factor at constant level. The allowable cavitation number is often by over two times higher than the critical one, corresponding to the abrupt turbine efficiency fall.

Despite some ambiguities in the technique of determining the allowable cavitation number under lab conditions, there exists a statistically and theoretically confirmed dependence (Figure 15) on the specific speed value, often approximated by the formula

$$\sigma_{Th \text{ allowable}} = (n_{sQ} / S_Q)^{4/3}$$

with  $S_Q = n Q^{0.5} / NPSH_{\text{allowable}}^{0.75}$  denoting the suction specific speed and varying usually between 0.85 and 1.0 for Francis turbines and between 0.65 and 0.8 for Kaplan ones (with lower values corresponding to higher specific speed) (Pfleiderer and Petermann, 1986).

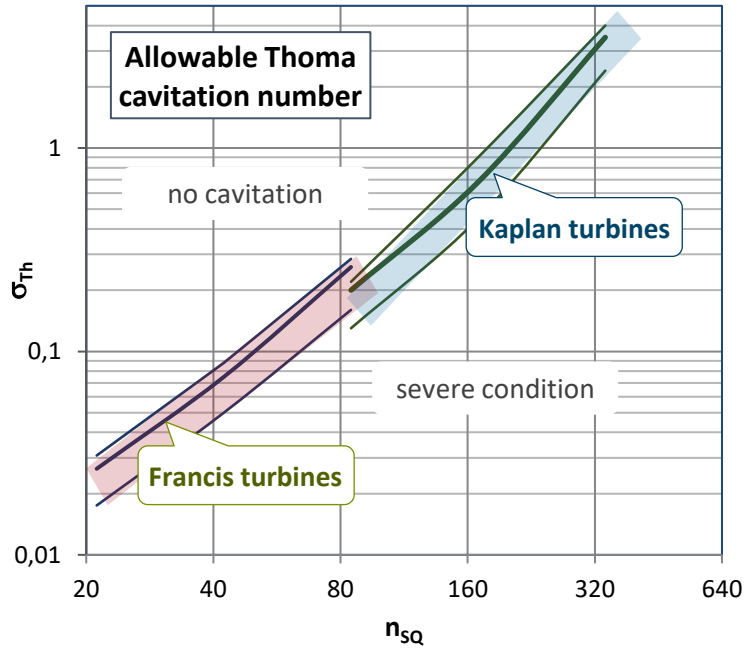

Figure 15: Cavitation limit curves vs specific speed coefficient (after Arndt, 1981)

### 3.1.2 High head turbines

#### Pelton turbine

Among various hydraulic turbines, the Pelton turbine (Figure 16) is the machine most suitable for high head, generally greater than 200 m for large hydro and 80 m for small hydro. Invented in the US in the second half of the 19th century, the Pelton turbine is widely used in Europe, especially in Alpine countries, and manufactured by numerous European producers, including both the largest ones and those oriented exclusively on the small hydro sector.

The world record of the most powerful Pelton turbine is 423 MW. The turbine is run at almost 1,870 m head in the Bieudron storage hydropower plant in Switzerland. The smallest units provide less than 100 kW on drinking water networks for a minimum head of 60 m. This turbine, which can be of horizontal or vertical axis, consists of a manifold distributing the flow to one or more injectors, a runner made up of shaped buckets and the pit. This type of turbine is an impulse ("action") machine since the hydraulic power is transferred to the runner in kinetic form through the jets, the runner rotating in the air. Therefore there is no static pressure difference at the runner inlet and outlet. The number of injectors is limited to two for a horizontal axis turbine, while there may be up to six injectors for a vertical axis Pelton turbine. The turbine power is adjusted by a needle valve, located inside the injector, whose stroke variation will modify the jet cross-section and consequently the flow. Jet deflector mounted at the nozzle end takes care of almost immediate cut-off of the runner propulsion without dangerous water hammer which would be inevitable when using the needle valve for this purpose. The jet being deviated, it is then possible to close the nozzle slowly.



**Figure 16: The 7 MW Pelton turbine of Gletsch Oberwald (CH) Hydropower plant (source: FMV SA)**

The runner converts the hydraulic power into mechanical power. This mechanical power transferred to the turbine shaft is then converted into electrical power by the generator. For small hydropower, this type of turbine is often installed on drinking water networks or at diversion type run-of-river small power plants with the constraints of an atmospheric pressure at the outlet. In case of a needed residual relative pressure at the outlet, counter pressure Pelton turbine can ensure such conditions (a small compressor is used to pressurize the casing and keep the downstream level sufficiently below the runner). Thanks to its injectors, this machine can maintain a good efficiency (90 % and more) over a large variation of the discharge. Nevertheless, head variation of multi-jet units is limited due to Falaise effect consisting in interaction of an impacting jet with water having not left completely the bucket after the previous impact (Perrig, 2007).

In small hydro, Pelton turbines are widely used in drinking water turbinning schemes and on run-of-the-river sites with high head and strong flow variations.

### Turgo turbine

The first prototype of Turgo turbine was designed by a British engineer Eric Crewdson and manufactured by Gilbert Gilkes & Co Ltd (today Gilbert Gilkes & Gordon Ltd) as early as 1919. Since then the company remains the main supplier of Turgo with reference list of over 1,000 units.

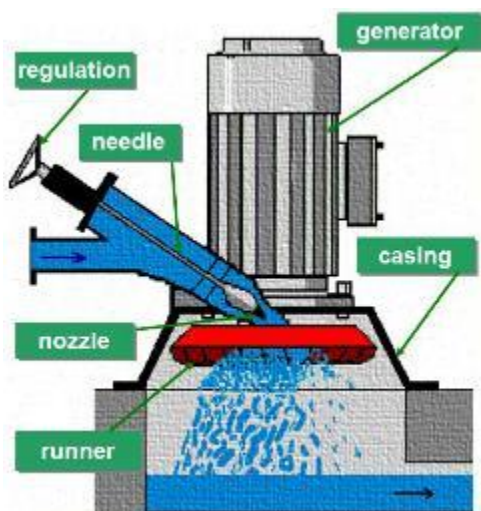

**Figure 17: Schematic of single jet Turgo unit (Mala voda, 2020)**



**Figure 18: A simplified Turgo turbine model (Hartvigsen Hydro, 2020)**

Although developed as a far going modification of L. Pelton's design, the Turgo turbine concept (Figure 17 and Figure 18) resembles directly that of a traditional Balkan bucket wheel mill in which the unpressurised wooden

conduit has been replaced by a pressurised piping with a modern needle nozzle and the wooden bucket wheel – by an optimised steel runner. A copy of a 19th century Turgo predecessor is exposed in the German Museum of Science and Technology in Munich.

The contemporary Turgo turbines are highly optimised units offered by Gilkes in 16 vertical and horizontal shaft versions for small hydro applications within a head range between 100 and 300 m and up to 10 MW capacity limit. Some other companies offer Turgos also for lower heads. According to Gilkes (2019) the main advantages of Turgo turbines include simplicity of construction, reliability (especially when handling silty or abrasive water) and good efficiency for a wide range of flows. In fact, the turbine efficiency is only slightly below 90 %. The Turgo turbine shows also a higher specific speed than a Pelton one of the same capacity which implies higher output at the same size.

### 3.1.3 Medium and low head units

This group of hydropower machinery is especially rich one as in addition to the traditional turbines with mixed- (Francis), diagonal- (Deriaz), axial-flow (propeller and Kaplan) runners it covers also cross-flow turbines, pumps as turbines and such innovative designs as VLHT (Very Low Head Turbine).

#### Francis turbine

With its roots reaching S. Howd's US patent of 1836, and further contribution of such designers as J.B. Francis, C.L. Fink, A.M. Swain, A. Pfarr and others, the radial-axial flow turbine called after the name of its "re-inventor" and enhancer, reached substantial maturity as early as the end of the 19th century. Shortly afterwards Francis turbines represented already the most widely used water turbine type with head range from well below 10 meters up to several tens and some time later - several hundred meters (up to 700 m). Today, Francis turbines with capacity well over 800 MW (Xianjiaba Hydropower Plants, China), are the most powerful hydraulic turbines used worldwide. Although their significance in the field of low head hydro fell gradually with ever wider deployment of the V. Kaplan's invention of axial-flow runner blade adjustment system, still in the beginning of 1980s the low head Francis turbines were able to keep their predominating position among micro and mini hydropower installations. Most of low head applications concerned turbines installed in an open turbine chamber –sometimes formed as a semi-spiral one - with external wicket gate (guide vane) adjustment mechanism. Horizontal (single and twin turbine) configurations with shaft passing through the turbine chamber wall were very frequent (Figure 19). The essential change came with advent of compact double-regulated axial-flow (tubular) units with a number of technical advantages and reasonable price level.



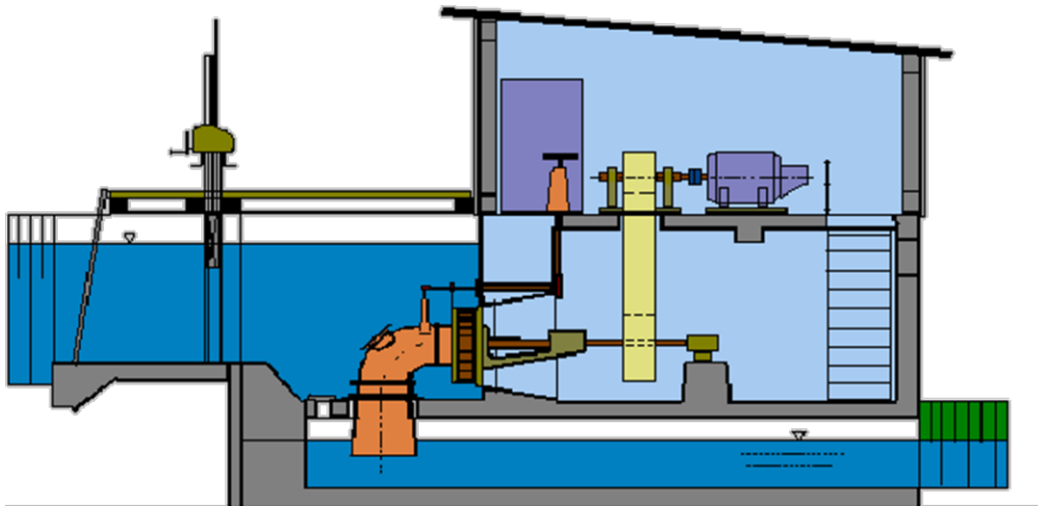

**Figure 19: An old fashioned small low head Francis turbine configuration (after Hoffmann (ed.), 1992)**

Today, Francis turbines remain still the optimum solution for numerous small hydro power installations with a head above 10 m. Their advantage is due not only to the reasonable price, but also to high quality of the flow system, manifested by high efficiency and satisfactory cavitation properties. The last feature allows installation with positive suction head and reduced civil engineering work costs. The modern small Francis turbines (Figure 20) are usually equipped with a steel spiral case and modern wicket gate safety mechanisms, e.g. with gaseous springs. Advanced composite materials are used for seals and water lubricated slide guide bearings as applied in vertical configurations.



**Figure 20: A modern Francis turbine in a refurbished Polish hydropower plant (source: IMP PAN archives)**

Francis turbines of above 100 kW capacity are often used in the energy recovery systems, in which one cannot guarantee constant flow conditions (e.g. urban water supply systems). The disadvantage of this type of turbines is rather steep efficiency vs discharge characteristics (Figure 21). In case of large turbines great care must be attributed to the partial load operation which in the past was often allowed only down to 60 or 65 % of the full load. The partial load dynamic effects are generally much less detrimental in small units. Nevertheless, also in this case care is usually taken nowadays to take partial load operation into account already at the turbine design stage.

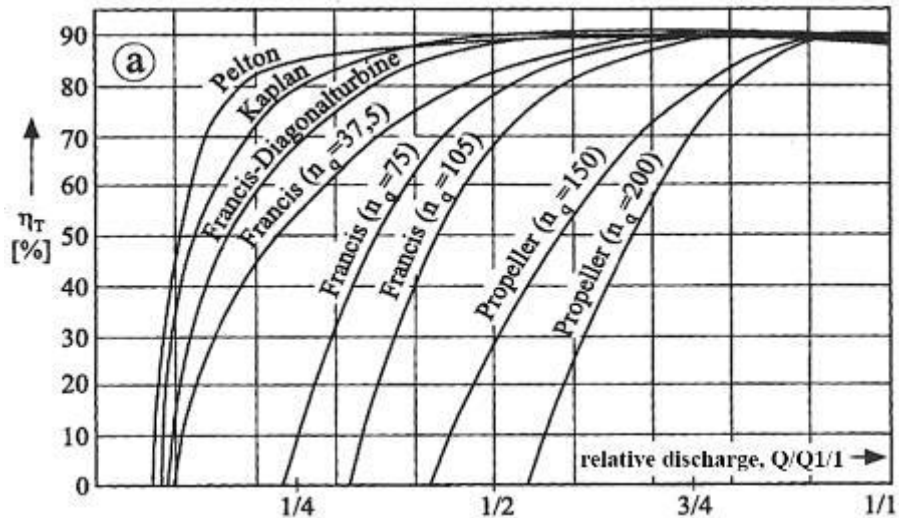

Figure 21: Typical efficiency curves of hydraulic turbines (Raabe, 1989)

### Axial-flow turbines

Axial-flow turbines with adjustable guide vanes (propeller turbines) were known already before World War I, but it was the V.Kaplan patent on regulated runner blading which brought a major breakthrough in the end of war period. Double regulation had allowed running the turbines with good efficiency over a wide range of discharge which was of fundamental significance for operation under variable hydrological and/or grid conditions. Due to this reason, within the next decades Kaplan turbines covered the whole low and medium head turbine application area (Figure 2). Moreover, the efficiency characteristics of single regulated turbines with adjusted runner blades (so called semi-Kaplan units) has appeared much less steep and therefore more advantageous than that of propeller turbines. This observation had a profound impact on development of low head turbines for small hydro sector. The classic Kaplan turbines are equipped with radial distributors comprising spiral or semi-spiral cases, as well as radially positioned stay and guide vanes (Figure 22). In some small installations, a siphon configuration is used.

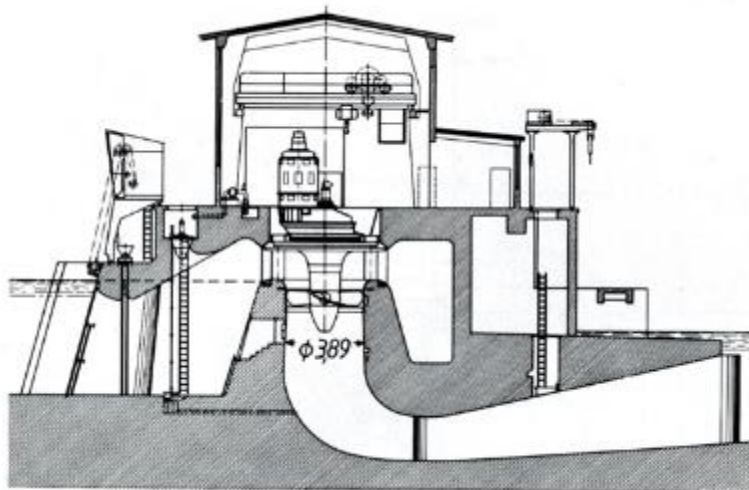
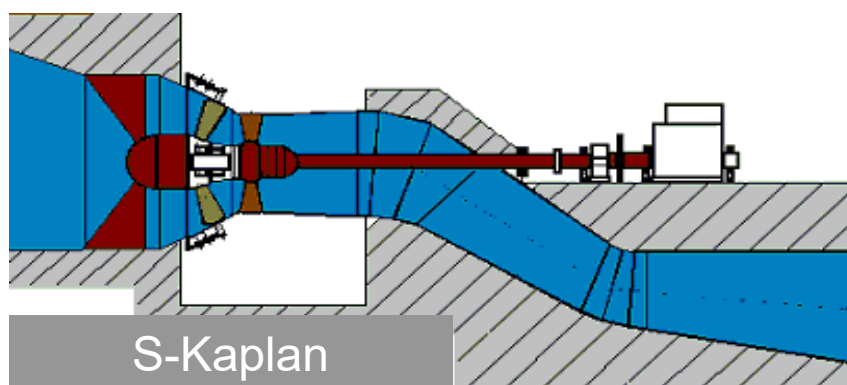

Figure 22: Classic Kaplan turbine in siphon configuration. Marktbreit SHP (H =2.5 m, P =1100 kW) - Main, Germany (source: Raabe, 1985, after Voith)

An innovation of high significance for low head applications was the introduction of tubular units - originally proposed as straflo (straight flow) ones by L. S. Harza, then implemented by Escher Wyss both in bulb and straflo versions in a number of rather small German installations. In the 1960s and 1970s, both concepts eventually

evolved to units mounted mainly in large hydropower plants. The characteristic feature of these designs was mounting the generator with gearbox inside the unit bulb or using the turbine runner as a generator rotor (with stator windings located at the runner chamber rim). The obvious advantage of tubular design in comparison with the classic (with radial distributor) one is efficiency increase due to avoiding the 90° bending of the flow direction and substantial decrease in the amount of required civil engineering works. The disadvantages include relatively large bulb size, high costs of unit installation, maintenance and overhaul. These aspects and some technical problems – mainly with sealing - had prevented their wide use for a longer time – especially in small hydro applications. In fact, the highly “elegant” classic straflo units are not widely used today, even if they may appear highly successful in some special applications (e.g. StrafloMatrix™ by Andritz). In the meantime, the term “straflo turbine” was extended also to small tubular turbines furnished with runner external rings used as a pulley of a belt speed increaser transmitting the mechanical power on the generator shaft (see section 3.3.2).

Irrespective of the mentioned Escher Wyss units, manufactured till 1951, the first small capacity tubular turbines were mounted in configuration with turbine shaft passing either through the delivery piping or draft tube elbow(s). In each case elbows must be designed with great care so as to avoid possible blocking of the flow. Some of these designs have appeared highly successful and are applied still today. The best established configuration is probably that of horizontal turbine with double elbow draft tube, usually called an S-turbine (Figure 23). In case of sufficiently high runner elevation the second elbow can be omitted. This option is recommended especially in small siphon installations in which case the use of a long heavy draft tube could be highly problematic.



**Figure 23:** Schematic vertical section of a low head SHP with an S-type tubular turbine. (After IEC 61116, 1992)

An example of a vertical shaft semi Kaplan siphon turbine with the shaft passing through the double elbow outlet tube is shown in Figure 24. This configuration is used in quite small installations. Its advantage is high simplicity and easy installation. Unfortunately, substantial hydraulic losses can be expected in the siphon and the draft tube.

From the point of view of hydraulic losses, letting the turbine shaft to leave the flow system through the inlet elbow is generally considered more advantageous. Figure 25 shows an example of a single elbow semi-Kaplan turbine configuration often considered the best matched to siphon applications.

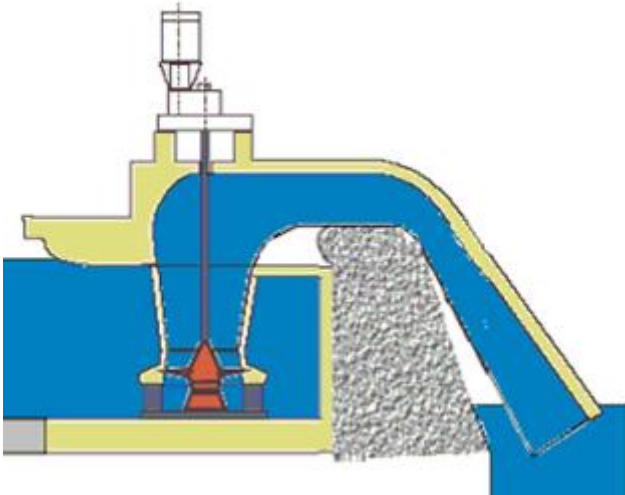

Figure 24: An inverted propeller or semi Kaplan turbine in a double elbow siphon configuration (ESHA, 2004)

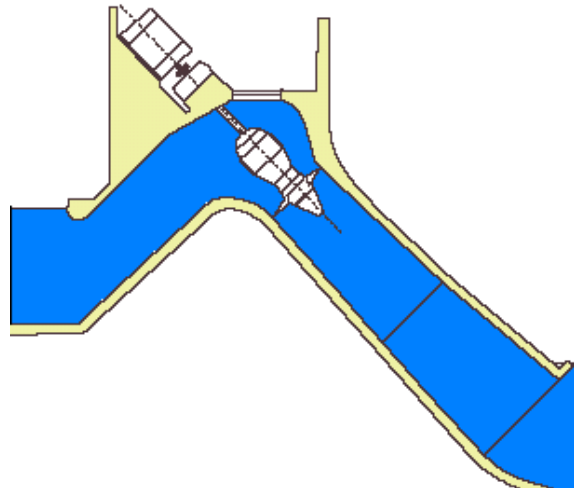

Figure 25: Semi Kaplan turbine in a single elbow siphon configuration (ESHA, 2004)

One of the best established tubular turbine configurations with shaft passing through the inlet side elbow is SAXO (Figure 26). Its main advantage in comparison with classic vertical Kaplan unit is saving space needed to erect the spiral case. However, as it can be seen from Figure 27 even higher savings in the civil engineering works (especially excavation), can be achieved by implementing horizontal configurations with a smooth inlet elbow passed the shaft (SAM configuration according to the former Alstom nomenclature (Czerwinski, Canas, and Marin, 2012). A disadvantage is of course the positioning of the runner immediately after the elbow, which results in in-homogeneous onflow conditions.

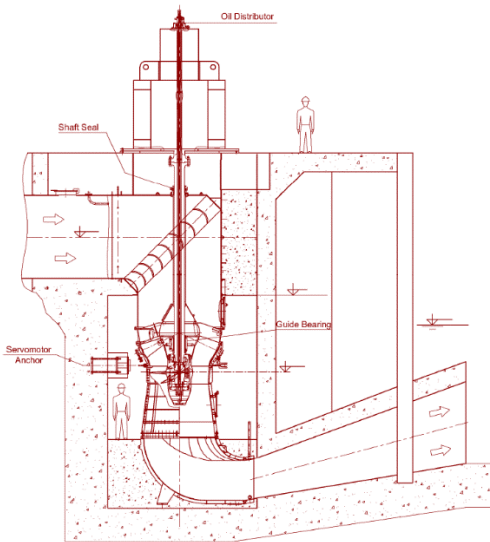

Figure 26: Kaplan turbine in SAXO configuration (Gale et al., 2010)

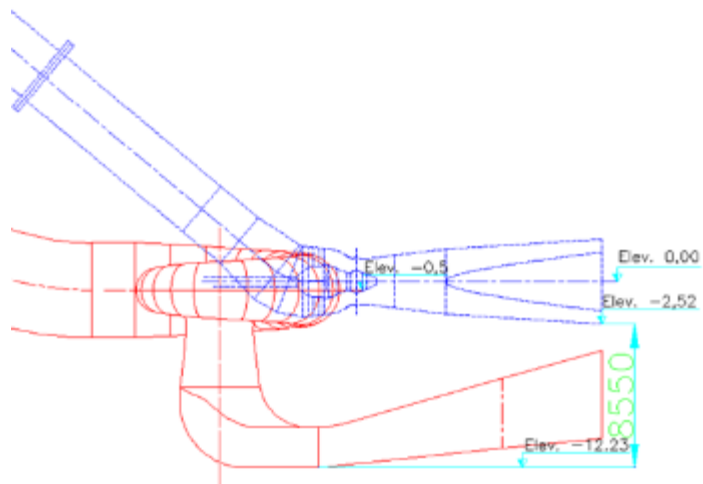

Figure 27: Comparison between excavation work needed for classic Kaplan turbines (2 units) and 4 tubular SAM turbines (4 units) with the same total capacity (Czerwinski, Canas, and Marin, 2012)

Efforts made to take full advantage of the tubular turbine flow system features and resign completely of the inlet and outlet elbows resulted already in the 1970s in the so called pit arrangement (Figure 28) with generator and gearbox located in a concrete pit flown around from two sides. Pit configuration is quite frequent in case of hydropower installations with capacity over 500 kW. Substantial progress in CAM techniques and material quality

refinement technology as applied to tooth gear manufacture allowed some time later to spread successfully another configuration. Nowadays, compact units with bevel speed increaser and induction electrical engine used as generator (Figure 29 and Figure 30) are probably the most frequently installed low head generating sets in a wide range of capacities - both in double and single regulated version.

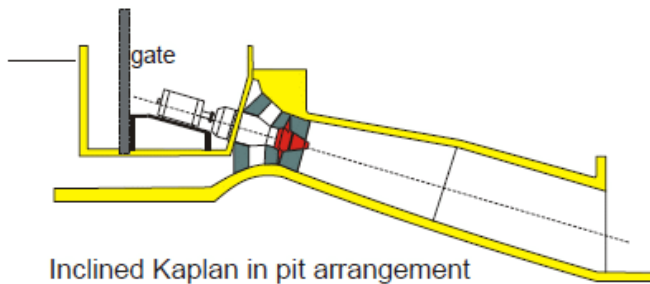

Figure 28: Tubular Kaplan turbine in pit arrangement (ESHA, 2004)

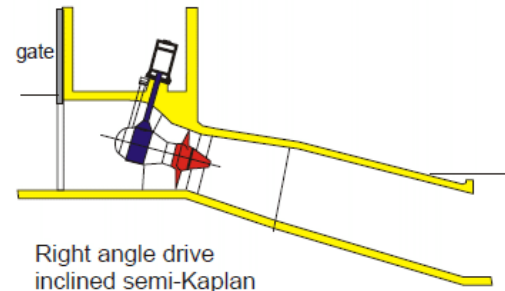

Figure 29: A compact semi-Kaplan unit with bevel speed increaser (ESHA, 2004)

The above mentioned progress in the mechanical engineering technology has shown also an impact on planetary gearbox implementation in compact submersible axial pumps. High gearbox ratio enabled using small size electrical engines and accommodating both devices in a small diameter capsule (bulb). The same design was applied in the end of the previous century in axial flow submersible turbines offered by some European companies. Later on, with advent of permanent magnet generators and spreading the electrical frequency conversion technology, this design stepped down from the foreground. The technological progress having taken place enabled omitting the gearbox, applying variable speed induction or permanent magnet synchronous generators and passing the task of securing the required frequency at the local or national grid connection point to the frequency inverter and other electrical power electronic equipment. Furthermore, the above solution has provided an additional hydroelectric unit regulation tool.



Figure 30: A typical compact unit with bevel speed increaser. Oborniki SHP, Poland (source: IMP PAN archives)  
Induction and permanent magnet generators are used among others in Hydromatrix and StreamDiver units delivered by Andritz Hydro (Figure 31) and Voith, respectively Cui et al. (2007), Keuneke (ed.) (2014) and Voith

(2020). Both are recommended for single and multiunit installations with scarce place and possibility to conduct any civil engineering work, e.g. at navigation and irrigation dams as well as abandoned ship locks.

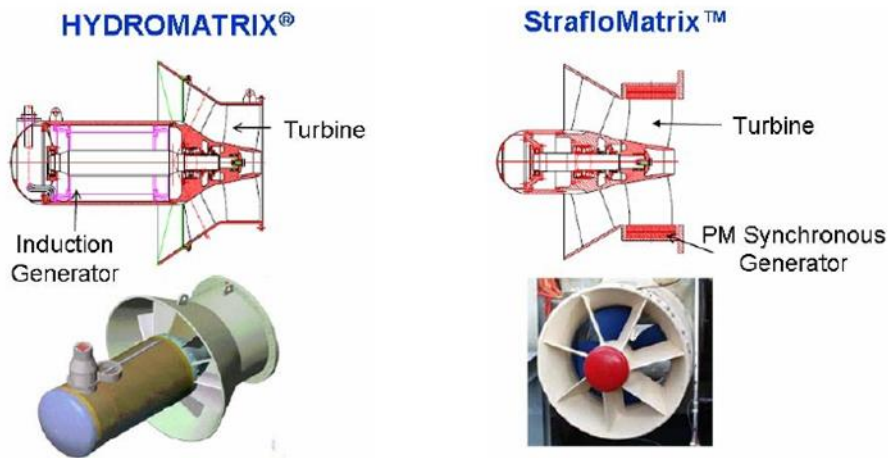

Figure 31: Hydromatrix® axial-flow units as offered by Andritz for installation in locks or weir gates (Cui, Binder and Schlemmer, 2007)

Another application of the permanent magnet hydro generator is that of the Very Low Head Turbine (VLHT) unit as developed by French engineers of MJ2 in the first decade of this century (Leclerc, 2008). Their main purpose is to harness the low head potential created by small weirs furnished with regulating gates. The concept was to replace the existing gate by a flap one comprising a large diameter axial-flow hydraulic unit with adjustable runner blades and variable speed permanent magnet generator. No civil engineering intervention except replacement of the gate is needed. Furthermore, low runner speed allows for keeping high efficiency without a draft tube and to avoid injuring fish passing the turbine (see section 3.9). The unit is recommended for operation with heads between 1.4 and 3.4 m (Figure 32).

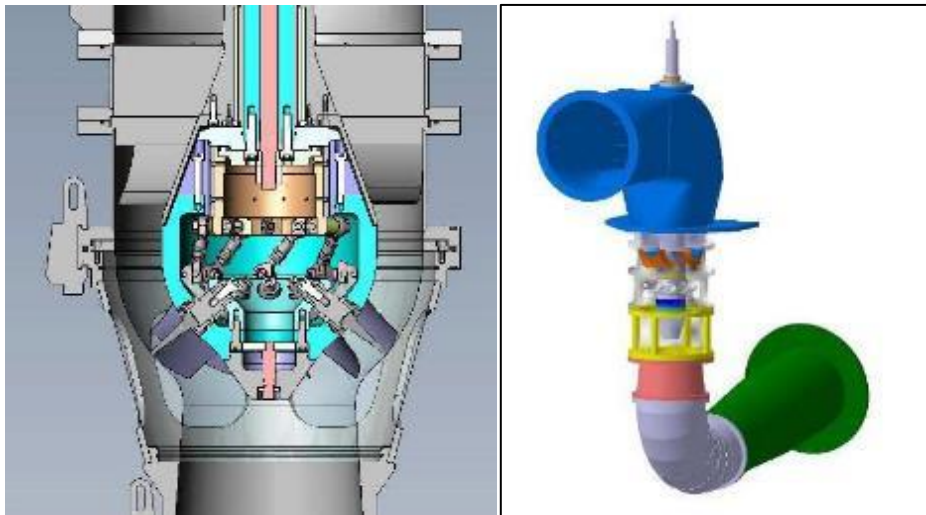

Figure 32: A VLHT unit at outlet of the Milleau canal (Leclerc, 2008)

## Diagonal turbines

The diagonal runner concept of P. Deriaz has allowed the inventor to introduce double-regulation into the medium head operating range. This is considered to be of particular value in case of large head variations, characteristic for medium head pumped storage installations. Runner blade adjustability has allowed to improve unit performance also in the pumping mode of operation. Wicket gate system is applied alternatively - in radial or diagonal configuration. As mentioned, the design is applied mainly in medium head pumped storage installations, although it is suitable in SHP run-of-river installations with higher flow variations.

Nevertheless, it was only in the previous decade when a single regulated turbine with Deriaz runner was developed by the Mhylab company (Montcherand, Switzerland) with the aim to provide higher flexibility in the mid head range than that offered by traditional Francis turbines. The axial type distributor with stiff guide vanes resembles the one used in some tubular semi-Kaplan turbines (Figure 33). The turbine is generally installed in vertical Z-type (SAXO) configuration. The assumed range of application is up to 1 MW with head between 20 and 80 m (Denis, Cottin and Choulot, 2016).



**Figure 33: The Mhylab diagonal turbine (Denis, Cottin and Choulot, 2016)**

A double regulated diagonal turbine was then developed by Mhylab for the same range of head with 8, 10 and 12 runner blades configurations.

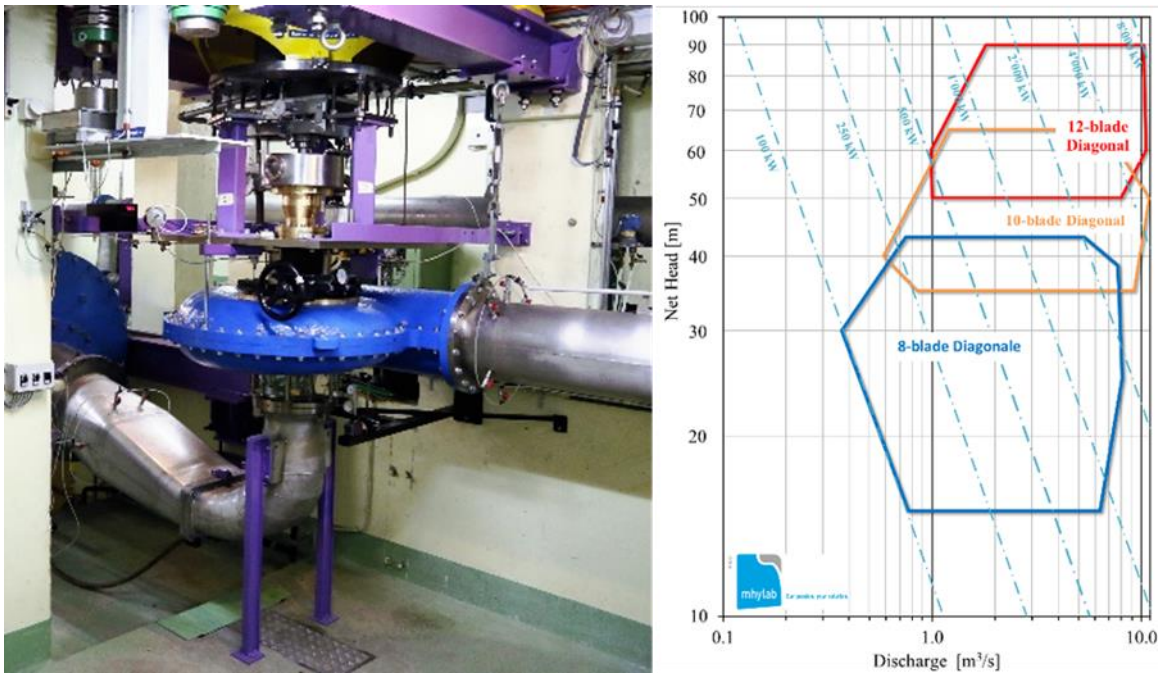

Figure 34: The Mhylab diagonal turbine (Bullani and Denis, 2019)

### Cross-flow turbines

The last medium head turbine to be mentioned in this survey is a cross-flow turbine, called also Banki-Michell one after the names of its independent inventors – Donat Banki, a professor of the Budapest University of Technology and an Australian engineer, A.M. Michell. Although the manufacturers are located worldwide, the most renowned one is the Bavarian company Ossberger. The company has introduced some important refinements. Due to this reason the turbine is called also Ossberger turbine (Figure 35).

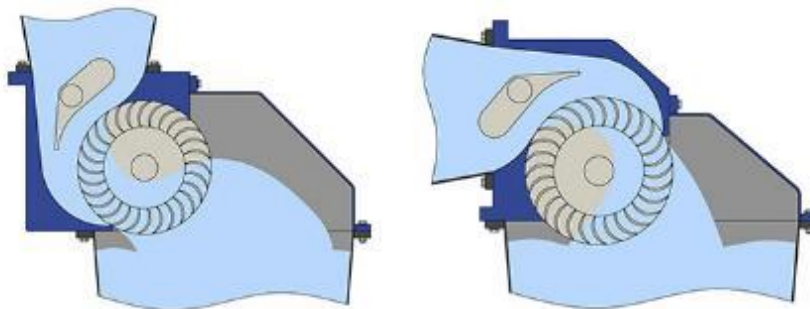

Figure 35: Cross-flow turbine according to the Ossberger concept (Ossberger, 2018)

The Banki-Michell turbine is essentially an impulse machine with a nozzle controlled by a single guide vane or a cylindrical gate blocking smaller or large portion of the runner periphery. The liquid leaving the nozzle hits the blades located at the cylindrical runner periphery, passes the runner internal space and crosses the blade cascade ring again when leaving the runner. Therefore it is considered sometimes a double stage machine with lower runner edge level used as reference when calculating the net head. The turbine shows some degree of reactivity which can be controlled by an air valve or an optional draft tube. Due to energy loss between the runner lower edge and the tailwater, the turbine is generally not recommended for the lowest head. This limitation has been removed by a Czech engineer, M. Cink, who developed a reactive version of the turbine (with a draft tube) known under his name (Pucher, 1996). However, due to high cavitation risk, the recommended application range of reactive cross-flow turbines had to be shrunken to 1 - 3 m with sure impact on efficiency. Cavitation in a cross-



flow turbine can lead to significant vibro-acoustic and erosive effects. Precautions to avoid water penetration into the bearings are needed if bearing pitting is to be avoided (CINK Hydro – Energy, 2020). As vibration may occur also in non-cavitating turbines, stiffening reinforcements are often applied between the runner blades. This measure does not only improve the runner strength properties, but also moves its resonance frequency upwards – possibly above that of hydraulically generated vibration stimulations. The disadvantage is lowering the efficiency due to increased friction losses and increased risk of clogging in case trashracks do not prevent inflow of leaves and weeds.

The Banki-Michell turbine efficiency – with head measured to the lower runner edge – is often below 80 % and always below 85 %. The reason lies mainly in the design not allowing to keep to the design inflow angle at whole runner circumference crossed by the stream of liquid, the highly turbulent flow nature inside the runner and some other effects leading to energy dissipation. Nevertheless, the turbine is considered still a robust and cost-effective option in numerous small hydropower applications.

The advantages include pretty simple and easily repeatable design and maintenance. The manufacturing technology may be considered not very complicated provided due attention is paid to some sensitive aspects with impact on vibration susceptibility and lifetime. The nice operational feature is the possibility to flatten the efficiency curve by dividing the guide vane and runner flow system into several segments (typically 2 - 4) run as separate moduli. High interest in the Banki-Michell turbines is manifested by a large number of technical and scientific studies reported from the non-European countries.

### **PATs and other energy recovery turbines**

In case of smallest installations featured by rather constant operating conditions, use can be made of pumps run in the turbine operation mode. Efficiency at the optimum operation point is usually between 65 and 75 %, occasionally exceeding 80 % (Fontanella et al., 2020). This is by 10 to 20 % less than in case of classic turbines (such as Francis and Kaplan). Furthermore, due to steep efficiency characteristics, proper matching the best efficiency point to the operating conditions is of key significance. However, due to serial manufacture and relatively low price, Pumps As Turbines (PATs) appear often an economically justified choice both for energy recovery installations in municipal water networks or industrial hydraulic systems and for some classic micro hydropower applications. Regulation is generally possible by rotation speed adjustment or head lowering techniques.

Usually single stage centrifugal pumps are deployed in the operating range between 10 m up to almost 200 m. Some large European pump manufacturers, like KSB, have acknowledged significance of such implementation of their product and tested their pumps in the turbinning mode of operation (Figure 36).

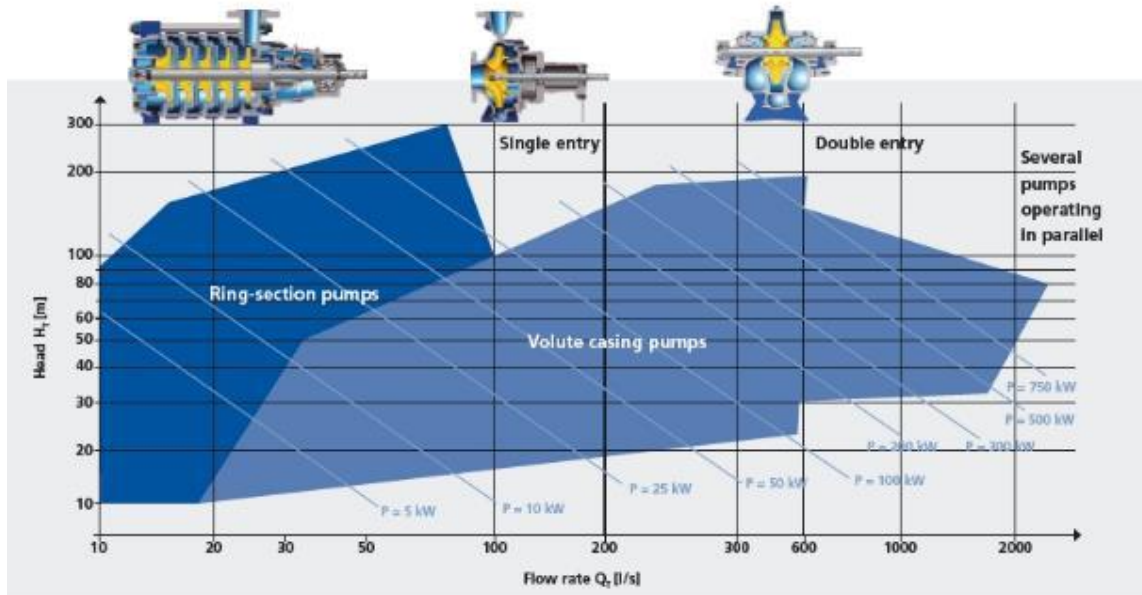

Figure 36: Pumps for turbine operation as offered by KSB AG (KSB, 2012)

In order to complete the technologies portfolio for small hydropower on existing infrastructures, new turbines are under development. At HES SO Valais, a new turbine called Duo Turbo (Figure 37) has been developed in collaboration with EPFL and industrial partners to harvest the energy of drinking water networks. One stage of the DuoTurbo microturbine consists of two axial counter-rotating runners, each one featured with a wet permanent magnet rim generator with independent speed regulation. This compact design enables a serial installation to cover a wide range of hydraulic power. Two prototypes of a one stage Duo Turbo have been installed in 2018 and 2019 on pilot sites with an installed power of 6 kW recovering a head between 20 m and 80 m and a discharge between 5 l/s and 20 l/s. The relative rotational speed of the two runners allows a good efficiency for a large variation of head and discharge compare to PAT technology.

An urban version of the Duo Turbo (Figure 37) will be installed in 2021 in distribution drinking water networks of large cities to provide solutions for smart cities development enduring large pressure variations.

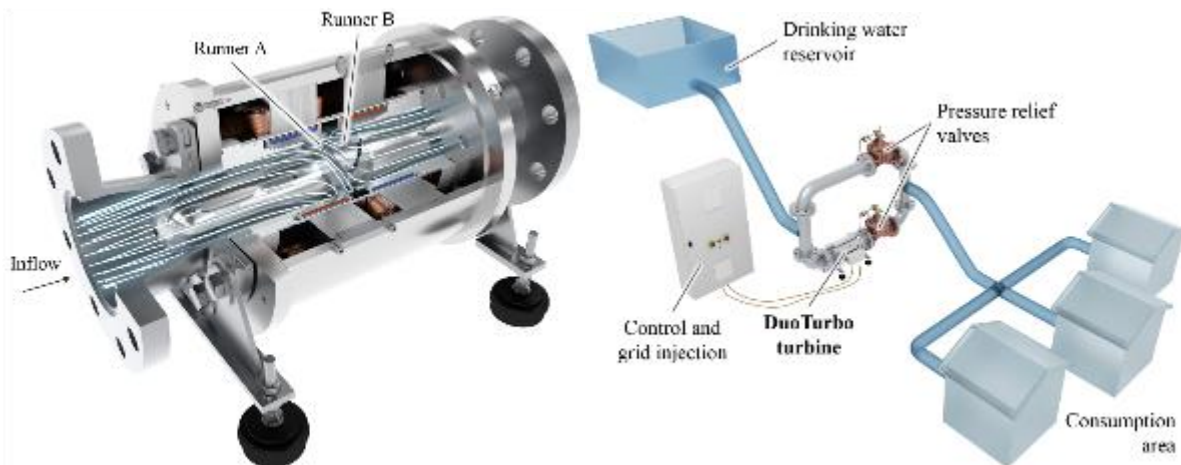

Figure 37: Duo Turbo turbine developed at HES SO Valais (Biner, 2016)

### 3.1.4 Hydrokinetic units

The concept of exploiting kinetic energy of flowing waters is quite old as the documented usage of undershot wheels is dated for the 3rd century B.C. In fact the undershot wheels are not pure kinetic engines as they are

installed at small weirs and water hits the wheel paddles at some elevation over the tail water level. The specific kinetic energy of water flowing in the millrace is therefore much higher than that in the free flow upstream the weir and gravitational energy is partially used for driving the wheel. The contribution of gravitational energy is even higher in case of the so-called breastshot or Zuppinger wheels. The situation is different with the stream water wheels installed in the past at the floating mills. In this case only kinetic energy of free water stream is available for propulsing the wheel and milling machinery.

Due to efficiency not surpassing 50-60 % and other disadvantages (low speed and high dimensional requirements) typical for all water wheels, the undershot or even breast shot wheels had to step down from the foreground in the mid of the 19th century. Nevertheless, there exist today highly experienced and successful suppliers of water wheel driven hydroelectric units (Figure 38). Their application field is rather narrow, oriented often on restoration of sites considered the industrial heritage of the past. On the other hand, the modern power electronic technology is helpful in avoiding excessive losses in the power transmission chain.



**Figure 38: A water wheel unit model by a Bavarian company of Walter Schumann at the annual RENEXPO Interhydro fair in Salzburg, Austria (source: J. Steller)**

The concept to exploit the kinetic energy of flowing waters came again to broader interest in the second half of the previous century. Firstly, the advanced compact units with small propeller turbines were found a reasonable source of electricity for some remote sites with no access to the grid, very low demand and situated in vicinity of water courses with at least locally swift water flow. The second reason was the politically motivated support from European governments and NGOs. Another aspect was the development of kinetic turbines for ocean related to a large potential of offshore electricity productions on the costs of Europe. Similar technologies can be used for river applications.

Although having a lower efficiency than the hydraulic turbines there might still be a financial advantage for hydrokinetic turbines. The LCOE (Levelized Cost of Energy) is determined by dividing the overall cost volume of a power plant occurring in its lifetime (investment and operational cost) through the overall energy generated. It is an important investment criterion and might be in favor of kinetic turbines as they could require lower investment costs regarding civil works etc.

The “efficiency” of kinetic turbine is calculated as a power coefficient defined as:

$$C_p = \frac{T \cdot \omega}{0.5 \rho \pi R^2 V_\infty^3}$$

This power coefficient is function of the tip speed ratio defined as:

$$\lambda = \frac{\omega \cdot R}{V_{\infty}}$$

For a runner in a free flow, this power coefficient is limited by the well-known Betz limit of 59.2 %. According to the type of kinetic turbine, the power coefficient is maximum for a specific range of the tip speed ratio.

According to the range of tip speed ratio targeted and power coefficient, different technologies can be selected (see above Figure 12). One characteristic is the axis orientation: cross-flow turbines or horizontal axis turbines, another one is the use of a venturi duct to exceed the Betz limit or let the runner in the free flow (Figure 39 and Figure 40).

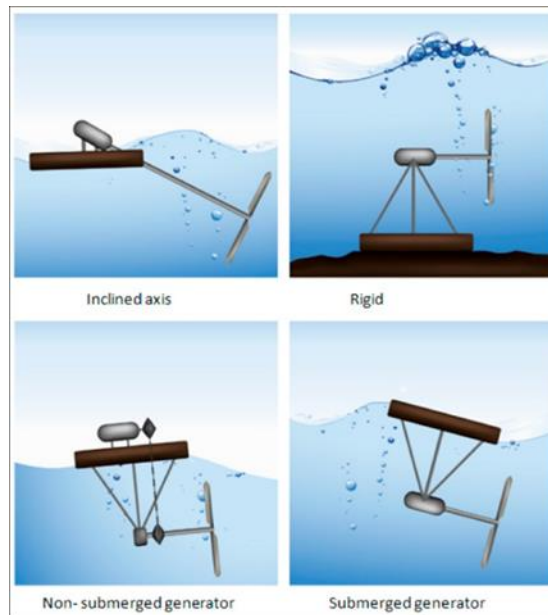

Figure 39: Non-ducted turbines with horizontal and flow adapting axis (Khan, 2009)

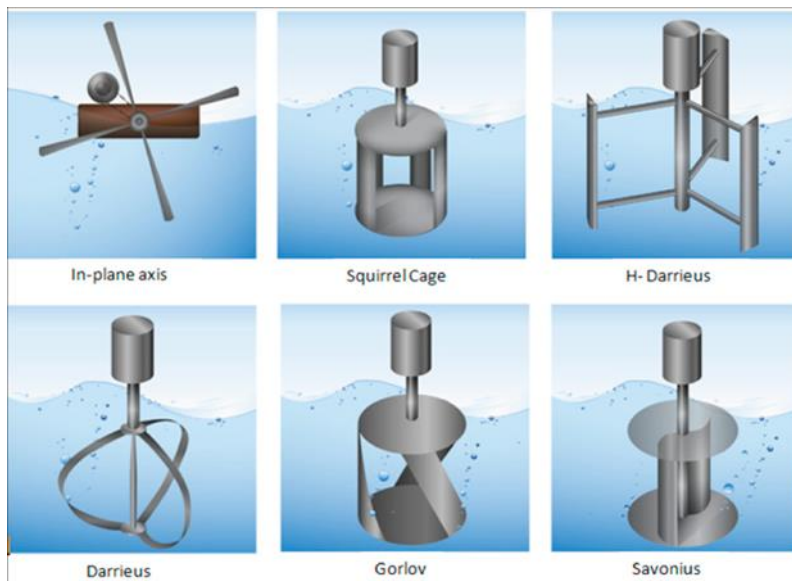

Figure 40: Vertical axis kinetic turbine (Khan, 2009)

In case of no access to large and deep rivers with swift water current, the use of hydrokinetic propeller turbines in inland waters is generally limited to covering the most essential and highly localised electricity demand. The key advantages of this kind of installation include good mobility and robustness due to frequent use of floating units with ducted propellers. Among other successful European designs one should mention those of KSB, Smarthydro and REhydro companies (Keuneke (ed.), 2014).

A design recommended often for recovery of hydrokinetic energy from artificial and natural canals consists in employing units with axis perpendicular to the inflow direction. In this context it is worthwhile to mention an attempt to use for this purpose the Banki-Michell runner undertaken a decade ago by a Norway based Deep River company. Due to a rather small power coefficient no further progress in this direction has been reported later on.

The design of most hydrokinetic cross-flow turbines is based on concepts of Finnish and French engineers, Sigurd Savonius and Georges Darrieus, who patented their inventions as early as 1925 and 1931, respectively. In both cases the wind power applications were endeavoured by the inventors. Due to their relatively high power coefficient (see Figure 12), only Darrieus turbines and their descendants are discussed in the text below. In distinction to the Banki-Michell runner, only few blades are used in case of cross-flow turbines based on the concept of G. Darrieus. Of course, there is an exchange of angular momentum between the rotating assembly and the liquid. The torque at the shaft results from positive balance of moments from individual blades. The blade with its leading edge directed towards the onflowing liquid exerts the highest moment. At the same time negative angular momentum is transmitted to the liquid. A lot of research and development work on optimising blade geometry and configuration has resulted in a number of descendant designs such as H-Darrieus, Achard, Gorlov and Lucid turbines (Figure 40). Although the last two ones are of non-European origin they are at the same time important enough to be mentioned in this survey for the sake of completeness. The classic and H-type Darrieus as well as Achard turbines are used mostly in vertical configuration which is a substantial advantage allowing to keep the generator above the free water surface. Another advantage of a vertical configuration is the opportunity of an easy installation in an open flume which can increase their power coefficient, generally considerably smaller than that of the propeller ones.

Regarding the power which can be harvested to the river current, whatever the technology, the water velocity upstream to the turbine,  $V_\infty$ , is of key significance, since the raw power flux grows proportionally with  $V_\infty^3$  (see definition of  $C_p$ ).

Table 3 shows the undisturbed flow velocity influence on raw power flux density and the capacity of an exemplary hydrokinetic propeller turbine of  $D = 500$  mm swept area diameter and high power coefficient of 46 %. As it can be seen, some most basic needs - essential lightening, charging of batteries etc. at a single household can be met only in case of local velocity close to 3 m/s which is rather an extreme value - available only locally, possibly creating installation and maintenance problems. Attaining the same result with still high velocity of 2 m/s requires already swept area of almost 1 m diameter which is possible only in case of swift and relatively large rivers. Well anchored floating installations are generally used for this purpose (Saini and Saini, 2019, Keuneke (ed.), 2014, and Khan et al. 2009).

**Table 3: The equivalent head, power flux density and maximum output to be expected from highly efficient non-ducted hydrokinetic propeller turbines of various tip diameters**

$V_{\infty}$	$H$	$\varepsilon$	$P_{D500}$	$P_{D1000}$	$P_{D2500}$	$P_{D20000}$
m/s	cm	kW/m <sup>2</sup>	kW	kW	kW	kW
<b>1.0</b>	5.1	0.5	0.05	0.18	1.13	72.3
<b>1.5</b>	11.5	1.7	0.15	0.61	3.81	243.9
<b>2.0</b>	20.4	4.0	0.36	1.45	9.03	578.1
<b>3.0</b>	45.9	13.5	1.22	4.88	30.48	1950.9
<b>4.0</b>	81.5	32.0	2.89	11.56	72.26	

The axial velocity at runner cross-section can be substantially increased by installing the propeller at a diffuser inlet or in a venturi type duct. As reported in Khan et al. (2009), reaching a power coefficient as high as 1.69 should be possible. Of course, this increases also the installation size. Optimising the duct geometry has been a subject of numerous research and development studies within the recent years. The other method – feasible only in some artificial canals – is narrowing the canal width or lifting the canal bed at the installation site. This may contradict the canal design assumptions by affecting the canal discharge capacity and perhaps some other functional features.

One of the most successful hydrokinetic projects is that of Strom-Boje (Current Buoy). The unit is equipped with a two bladed propeller runner and a permanent magnet synchronous generator. The inlet segment is a large fin taking care of unit orientation along the main flow direction. Steel cables stretched on both sides of the inlet fin act as a self cleaning trashrack. Diffuser at the outlet side decreases pressure downstream the runner and increases flow velocity through the unit (Figure 41).

Strom-Boje was designed after the patented concept of an Austrian engineer, Fritz Mondl, and is manufactured now by the Aqua Libre GmbH and Aqua Libre Energieentwicklungs GmbH companies. Consecutive prototypes have been developed under support from various research and development projects since 2006. Since 2017 a commercial unit of 70 kW rated capacity is in successful operation in Danube close to the Kienstock locality. With runner of 2.5 m diameter, diffuser of outlet diameter 5.3 m, and weight of 7 tonnes, the unit generates 250 MWh per year which implies the average capacity of 30 kW at average flow velocity 2 m/s. The capacity achieved shows that velocity at the runner cross-section has been increased by nearly 50 %. The example shows also that an axial-flow hydrokinetic unit can be a source of a reasonable amount of electricity when installed in a large swift river with no prospects for damming. However, it should be borne in mind that only a small portion of kinetic energy available at the cross-section (typically 2 to 4 %) is recovered. A large hydropower plant - when erected at the same site at Danube river - would probably show capacity by four orders of magnitude higher. Achieving capacity compatible with a typical mini hydropower plant (several hundred kW) requires erecting a whole farm of large hydrokinetic units under favourable flow conditions. In fact, this is planned in Rhine river, in the so-called Middle Rhine, between the cities of Bingen and Bonn (Strom-Boje, 2020).



**Figure 41: Strom Boje 3 unit (source: Aqua Libre Energieentwicklungs GmbH)**

In Switzerland, a prototype of a ducted kinetic turbine has been installed in the tailrace channel of a large run-of-river power plants on the Rhone river to investigate the influence of local blockage ratio, the turbine depth and the tilt of the turbine axis (Figure 42). A power coefficient of 93 % has been reached for specific conditions. Long term on-site measurements are planned to investigate the robustness of the turbine and the environmental impact. Different sites for a farm of kinetic turbines are under consideration.

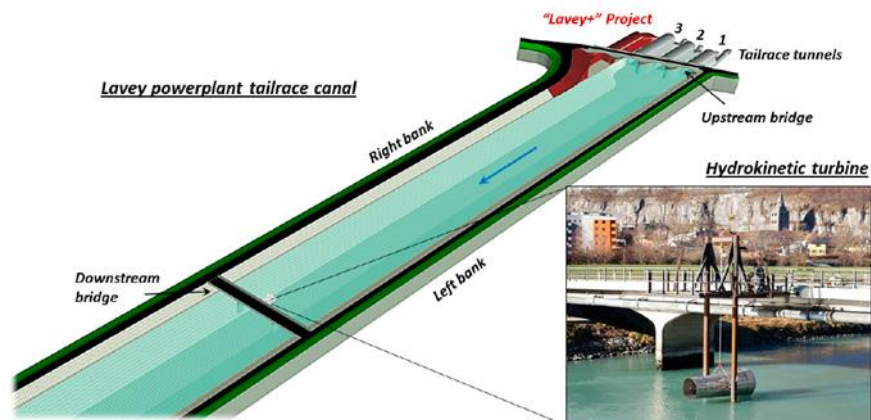

**Figure 42: Tailrace channel of Lavey HPP with the open-air platform to test the kinetic turbine prototype (Munch et al., Water 2018)**

In France, one of the more mature kinetic turbine is the Hydroquest technology (Figure 43) which has been installed on several pilot sites in Orleans and in Lyon.

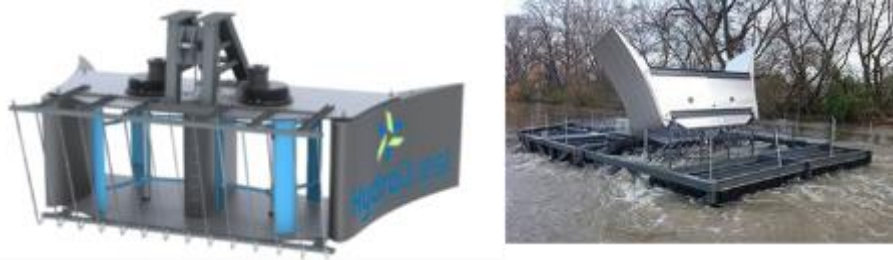

**Figure 43: Hydroquest technology tested in France (HydroQuest, 2020)**

The largest kinetic turbines farm in Europe was to be commissioned in 2019 on the Rhone River in France with this technology, close to the Genissiat Hydropower Plant with 2 MW of installed power, but the pilot project had to be abandoned for economical and technical reasons (Energies de la Mer, 2019).

### 3.1.5 Gravitational hydropower units

The historically documented appearance of gravitational hydropower units is dated for the 5th century AC, that is 800 years after that of undershot wheel and even some ancestors of the contemporary turgo turbines. The great advantage of an overshot wheel is its high efficiency, generally surpassing the threshold of 70 and sometimes even 80 %. The main disadvantages include very large size with wheel diameter compatible with the gross head and very low rotational speed resulting in excessive energy losses in the mechanical power transmission chain. The specific speed  $n_{s0}$ , as calculated with the formula used for turbines, is close or even smaller than that of the high head impulse turbines. Any attempt to increase the discharge results generally in excessive splashing of water out of the buckets and increased energy losses. Due to these reasons, the overshot wheel had to lose the competition with hydraulic turbines in the 19th century and step down from the scene in the first half of the 20th century - even if some 50 years later the low speed of a hydraulic unit could have been considered an advantage due to ecological reasons.

The response to a demand for a low speed and low head unit capable to generate electricity in an amount typical for other small hydro technologies while keeping the installation size in reasonable limits came in the end of the previous century. In 1992 a German engineer, Dr Karl August Radlik, patented the concept of applying the Archimedes screw, used so far in pumping applications, in a reverse direction - as a gravitational hydraulic engine (Figure 44). Some time later he supported Professor Karel Brada, of the Technical University of Prague, in his research on optimising the Archimedes screw parameters. The concept was not a new one as it was originally put forward in the beginning of 19th century by the famous French engineer C.L. Navier and 100 years later got even registered by W.Moersch in the US Patent Office. However, it was mainly due to efforts of Dr K.A. Radlik and Prof. K. Brada that the first pilot hydropower installation could have started its operation in Aufhausen, Bavaria in 1997. The first commercial installations followed in 2001 (Lashofer et al., 2013).

Archimedes screw, known in Germany as hydropower worm (*Wasserkraftschnecke*), is a typical gravitational engine. The shaft driving torque is due to the weight of water moving downwards in the buckets formed by the screw blading. Despite this rather simple principle of operation the device has been a subject of numerous research studies aimed at optimising such parameters as number of screw surfaces (blades), pitch, shaft/tip diameter ratio, shaft axis inclination angle. Further progress followed from technological experience, especially with high capacity units subjected to substantial static loads. Practical experience with variable hydraulic conditions has lead also to such innovations as variable inclination angle.



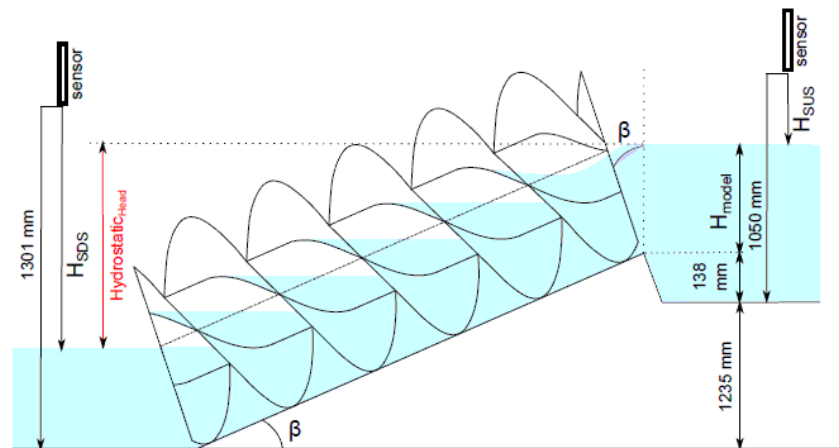

**Figure 44: Schematic view of an Archimedes screw runner showing instantaneous positioning of water in "buckets" formed by the screw blading (Rohmer et al., 2016)**

Today, the Archimedes screw may be surely considered as one of the most successful small hydro innovations introduced within the recent two decades. Archimedes screw based hydraulic units are manufactured worldwide by quite small, but also renowned companies. In numerous cases they are considered a low cost and environmentally acceptable alternative for a classic axial flow turbine.

From the technical point of view the high advantage is relatively high and flat efficiency characteristics, generally keeping in the 80 ÷ 90 % range for discharges above 25 % rated value. As shown by Lashofer et al (2013), typical efficiency of the whole hydroelectric unit is between 70 and 80 %. The disadvantages of rather limited regulation capabilities and high gear ratio could have been substantially mitigated by the use of frequency converters which allow also for rotation speed control.

The great environmental advantage - generally acknowledged by the environmental authorities - is fish friendliness. Archimedes screws are not only harmless for downstream migrating fish, but they can be also used as an active fish ladder or fish lift when run in pumping mode. Basically, there are two approaches used in practice. The first one is to use two units running in parallel: one as an electricity generator driven by an Archimedes screw in the hydraulic engine mode, the other one as a worm pump driven by a portion of electricity generated in the first unit (Figure 45, left).

The approach developed by the company Hydroconnect is more sophisticated. The pumping screw is mounted inside the tubular shaft of the first one. Thus, two units get integrated. The pumping screw is driven by water moving downwards through the external gravitational engine screw (Figure 45, right). In each case water flowing out from the hydraulic engine encourages fish to by the entrance to the lift. Despite high compactness, the design shows also some disadvantages which include problems with attracting fish to highly turbulent tailwater and rather imperfect technology of mechanical power transfer via two belt gears. The disadvantage of substantial landscape effect can be considered valid only in case comparison is made with the best landscape integrated classic SHPs.



Figure 45: A parallel Archimedes screw set by Rehart Power (left) and a 3D view of Hydroconnect coaxial screw unit (right) at the RENEXPO Interhydro Fair in 2017 (source: J. Steller)

The last hydraulic unit to be mentioned in this subsection is Steffturbine™. Despite its trademark, Steffturbine is not a hydraulic turbine at all, but a typical gravitational engine, successfully developed by the Walter Reist Holding AG, specialists in the belt conveyor technology. The driving force is weight of water flowing into consecutive buckets formed by non-corrosive paddles distributed on the belt (Figure 46). So the principle of operation is exactly the same as that in a backshot water wheel. Performance tests conducted in the Munich University of the German Armed Forces have shown surprisingly high efficiency between 85 and 90 % under favourable operating conditions (Baselt, Malcherek and Maerker, 2013).

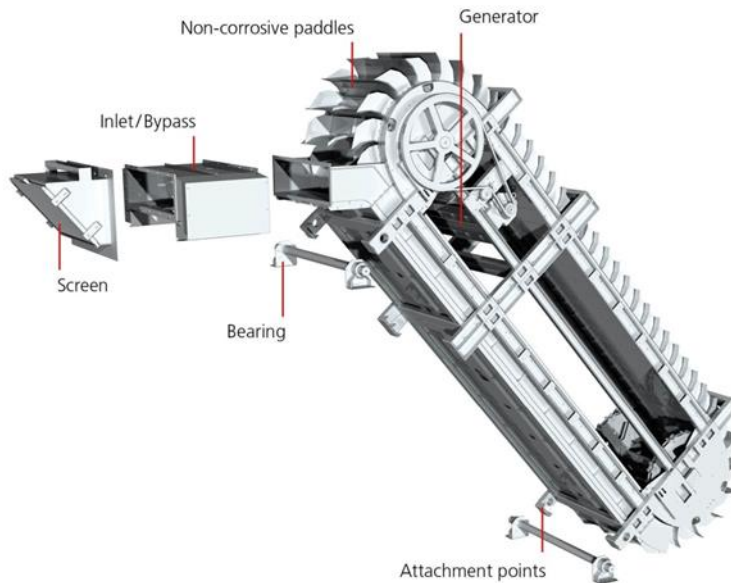

Figure 46: Steffturbine™ hydropower engine (Baselt, Malcherek and Maerker, 2013)

## 3.2 Gearboxes

In case direct coupling of the turbine and generator shafts is not possible – e.g. due to too low turbine speed - it is generally needed to use a speed increaser. Basically there are two kinds of speed increasers used hydropower:

a) tooth gears and b) belt drives.

### 3.2.1 Tooth gears

Tooth gears can be applied in full range of small hydro units. They can be mounted both inside and outside the turbine. The first solution is typical for bulb or vertical submersible turbines. In some cases the turbine bulb (capsule) comprises also the generator. In some other ones – only a bevel gear connected to the shaft of an external generator (Figure 47). An external gearbox is typical for vertical units and pit tubular turbines (Figure 48).

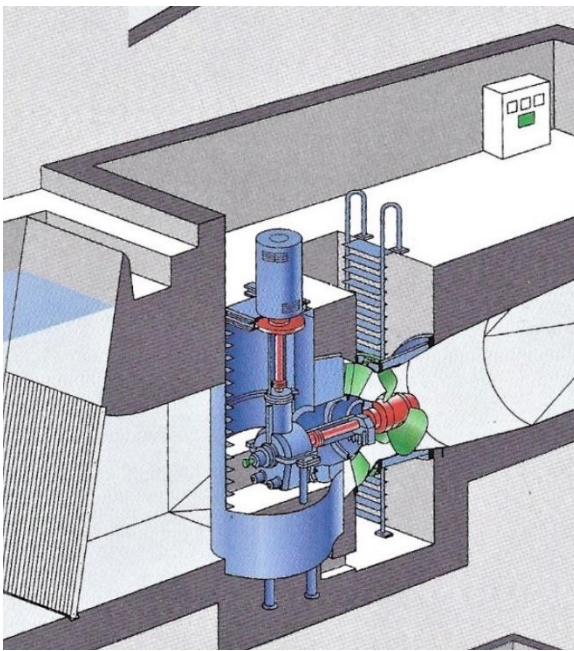

**Figure 47: Tubular pit turbine with a bevel speed increaser (Voith, 1990s)**



**Figure 48: Vertical Kaplan unit with a parallel shaft speed increaser (Eisenbeiss, 2016)**

The tooth gear can be connected directly or indirectly to the turbine shaft. In order to avoid any failure risk due to any misalignment and/or vibration, couplings are often applied. At least one of the couplings connecting the gearbox with turbine and generator shafts should be flexible.

In case of lower capacities the straight cut gears used. For higher ones – helical, double helical (Herringbone) and curved tooth gears (e.g. spiral bevel or hypoid gears) can be applied. The gear type and size are selected according to the turbine type and configuration (horizontal, vertical or inclined shaft) as well as generator situation.

The basic types of speed increasers to be used in hydropower units are as follows:

- spur gears (straight cut gears with cylindrical wheels, Figure 49);
- bevel gears (with conical wheels, Figure 50);
- planetary (epicyclic) gears (Figure 51).

Ensuring the expected lifetime and noiseless operation requires high manufacturing quality. Appropriate steels are to be used. The tooth surfaces should be hardened and grinded. High quality of alignment and bearings used as well as proper selection of lubricants are essential. The tooth gears as used in hydraulic units are generally designed as speed increasers and produced by experienced manufacturers. In some cases speed reducers are

also deployed. When selecting a speed reducer to be used as speed increaser the power capacity surplus is to be necessarily consulted with the supplier. In case of a typical spur speed reducers, the power capacity surplus ratio is  $f=1.5$ .

The main advantages of a tooth gears include compact structure and high efficiency (generally close to 98 %, depending on type number of stages and gear ratio). Among disadvantages one counts high manufacturing costs and possible noise emission.

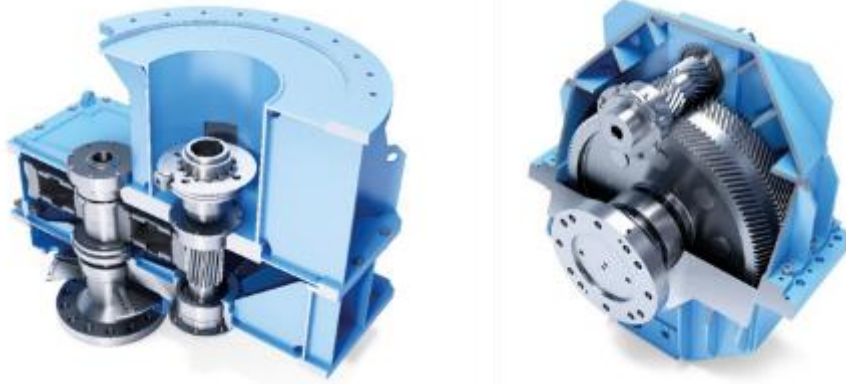

Figure 49: Spur gears dedicated for (left) vertical Kaplan and (right) pit tubular turbines (Eisenbeiss, 2016)



Figure 50: Bevel gears driving a horizontal (left) and vertical (right) generator (Eisenbeiss, 2016)

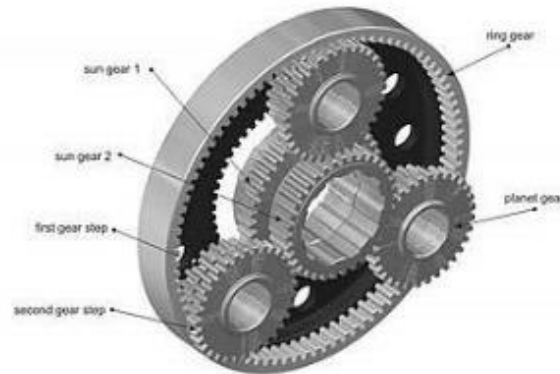

Figure 51: A double sun planet gear as offered by Rohloff AG (2020)

The progress in both material science and CAM technology having taken place in recent decades has shown a profound impact on the quality of gear manufacture. The capability to take over very large forces and transfer

considerable torques without increased risk of gear failure or shortening the average lifetime clearly favoured the development of compact tubular units with bevel gears. On the other hand, improving quality of planetary gears together with variable speed technology based on permanent magnet generators and current converters enabled a further decrease of the tubular turbine capsule size - at some stage, surely contributing to spread of the submersible units.

### 3.2.2 Belt Drives

Belt drives are generally used in hydraulic units with a capacity of up to 500 kW. The transmission belts can be divided according to their cross-sectional profiles as flat and V profiled (Figure 52). Additionally belts can be cogged. Cogged belts are also called toothed, timing and synchronous belts.

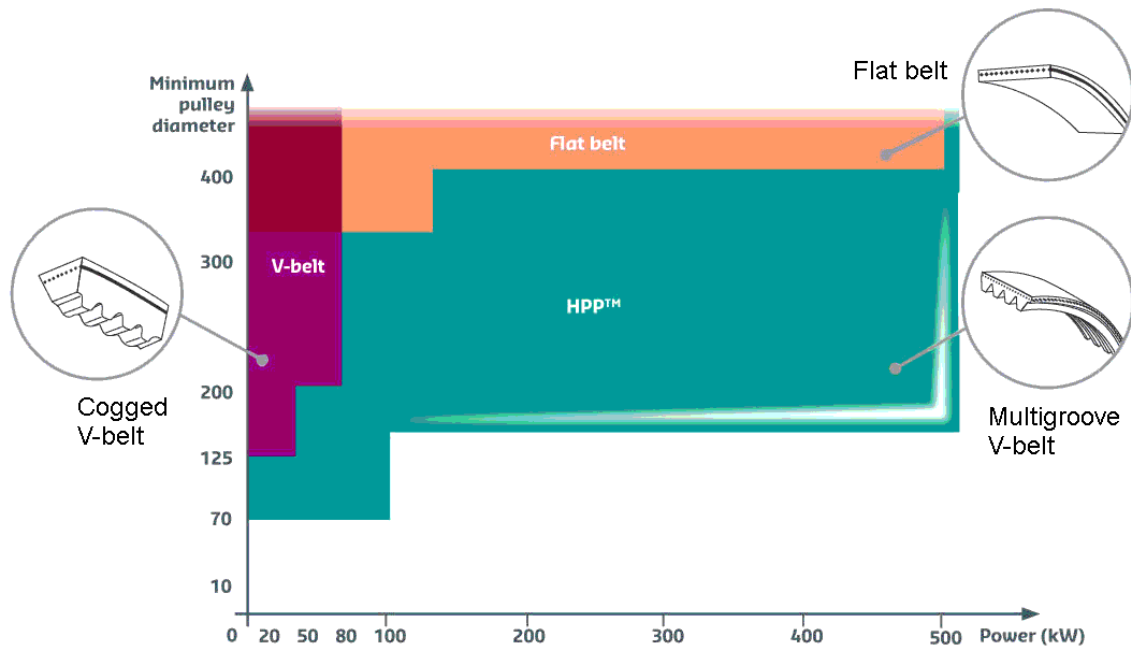

**Figure 52: Application range of 3 types of transmission belts as offered by Hutchinson (2020)**

Classic belt drives (Figure 53) transmit the torque from the turbine shaft onto that of the generator by friction between the pulleys and the belt in contact with them. The flat belt pulleys show slightly convex profile preventing the belt sliding down from the pulley. The V-belt pulleys are grooved.

Attaining the required friction force in flat belt drives requires substantial tension in the belt. Therefore it is recommended to avoid setting the turbine pulley directly on the turbine shaft. Using a separate shaft, connected to the pulley by means of a flexible coupling shows an advantageous effect on the turbine bearing system. The required contact angle between pulleys and the flat belt increases the distance between pulleys and results in much higher drive size than in case of a V-belt drive.



**Figure 53: Flat belt drives in micro hydropower installations (Burger Wasserkraftanlagen, 2020)**

V-belt drives transmit the torque with apparently increased friction coefficient which results in lowering the speed increaser size. Lower tension is required than in case of flat belts. Linked belts are generally recommended in V-belt drives. This solution ensures uniform load of all belts in a package and raises the drive lifetime.

The belt drive advantages include low noise operation and high efficiency. The flat belt drives show efficiency of about 99 % whereas the efficiency of V-belt drives is about 98 % and more. Their advantage in comparison with tooth gears lies also in much lower manufacturing costs. The general disadvantage is much higher size in comparison with the tooth gears and the need to adjust the distance between the pulleys.

In the past, flat belt drives were used quite extensively in small hydropower plants, also for torque transmission onto mechanical speed governors. Due to their low price they are still considered a reasonable option in some micro installations erected in place of old mills and equipped with vertical Francis turbines. V-belt drives are more frequently used in horizontal units.

In the recent decades the cogged belts are ever more often in use. Power transmission using the cogged belts is a very compact design option. As the torque is not transmitted by friction, the belts require minimum tension in order to avoid the belt teeth to skip those at the pulley rim. This feature increases substantially the lifetime of turbine bearings and allows to situate the driving pulley directly on the turbine shaft. At the same time one should notice that the cogged belt drives are more noisy than those with flat and V profiled belts.

Figure 54 shows an interesting example of combining the flat belt drive with a tooth gear based speed increaser in order to transmit the bulb turbine mechanical torque from the turbine runner rim onto the generator shaft. In the end of previous century this straflo configuration was considered an alternative for the small bevel gear units. Simplified versions, with turbine pulley situated in the bulb, were also manufactured.

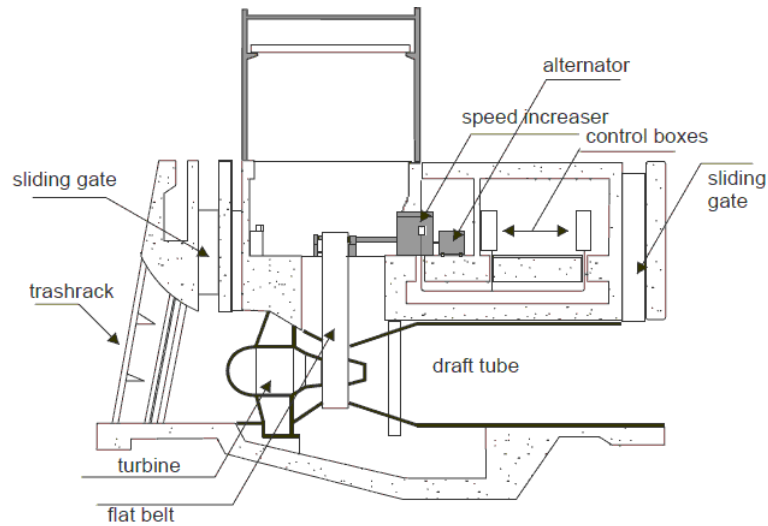

**Figure 54: A mini straflo unit with combined power transmission from the runner rim by means of a flat belt and a spur speed increaser (ESHA, 2004)**

Nowadays, gear boxes generally prevail in case of modern medium size small hydro units with turbine rotational speed below that of an 8-pole generator (375 rpm). The major part of progress linked with mechanical power transmission systems is linked with manufacturing technology allowing to produce gears and belts of ever higher durability. At the same time, permanent magnet generators with electrical power conversion systems successfully take over the function of mechanical gears in European micro and mini hydropower plants. More sophisticated, but still highly expensive, asynchronous generator based variable speed systems are also known from large hydro.

### 3.3 Generators

The mechanical energy of hydraulic unit rotating assembly is converted to electricity by means of generators. In practice, three kinds of AC three phase generators are encountered: synchronous, asynchronous and permanent magnet synchronous ones. The differences are essential as they concern both construction and principle of operation.

#### 3.3.1 Basic parameters

The most essential generator features are described by the following rated parameters: voltage  $U$ , power  $S$ , power factor  $\cos \varphi$ , frequency  $f$ , rotational speed  $n$ , excitation voltage  $U_{exc}$  and current  $I_{exc}$  (in case of synchronous generators).

The synchronous rotation speed [rpm] depends on grid frequency and the number of poles  $p$  according to the following relationship:

$$n = \frac{60 \cdot f}{p}$$

The rated voltage and current, as expressed in volts [V] and amperes [A], are defined in their effective values. Furthermore, the rated voltage term refers to the interphase voltage. The relationship between the interphase (line/line) and phase (line/neutral) voltage,  $U_{L-L}$  and  $U_{L-N}$ , respectively, is described by the dependence:

$$U_{L-L} = \sqrt{3} \cdot U_{L-N}$$

The generator power is expressed by means of the apparent power  $S$  expressed in volt-amperes [VA] and equal the sum of powers in all phases:

$$S = 3 \cdot U_{L-N} \cdot I = \sqrt{3} \cdot U_{L-L} \cdot I$$

The apparent power is a geometric sum of the active (useable) and reactive powers,  $P$  and  $Q$ , respectively:

$$S = \sqrt{P^2 + Q^2}$$

The active power generated by the generator and expressed in watts [W] is defined by the formula

$$P = S \cdot \cos(\varphi)$$

with  $\varphi$  denoting the phase shift between current and voltage.

The reactive power, expressed in VAR, follows from the formula

$$Q = S \cdot \sin(\varphi)$$

The reactive power can be of inductive (with voltage preceding the current) or capacitive (with current preceding voltage) character.

A significant parameter is also efficiency  $\eta$  defining the fraction of mechanical energy delivered to the generator shaft which can be converted into electrical energy, useful for the consumer.

### 3.3.2 Synchronous generators

Synchronous generators are usually applied in hydraulic units with capacity not lower than several hundred kW. The synchronous machine stator represents a three-phase AC winding whereas the DC winding (excitation) is comprised in the rotor. The excitation winding can be fed from a generator representing a part of the hydraulic unit (rotating excitation) or from a rectifier fed with an external source of electricity (static excitation). When in operation, the rotor and the stator magnetic field keep constant relative positioning (synchronous rotation) which is equivalent to keeping constant speed when running in parallel to a stiff grid. In case of a synchronous unit operated within an electrical power system, switching the generator to the grid is called synchronisation. The following conditions are required to be fulfilled:

- consistent phase ordering in the generator and the grid;
- consistent generator and grid frequency;
- consistent effective voltage at the generator and in the grid;
- consistent voltage phase shifts.

Synchronous generators fulfil an essential role in the electrical network by enabling capability of the standalone operation (island operation) and power system reconstruction (black start) as well as voltage and reactive power regulation. The disadvantages include higher deployment costs of synchronous units and the auxiliary systems.

### 3.3.3 Asynchronous generators

Asynchronous generators (Figure 55) are generally used in power plants of relatively small capacity (up to 1 MW). Typical induction engines are usually deployed for this purpose. The stator of this type machine takes the form of a three phase AC winding whereas the rotor represents a compact cage. When in operation, the rotor changes its positioning with respect to the stator (the rotor and stator magnetic fluxes move asynchronously one to the other). The asynchronous machine will run as a generator if its rotor speed is higher than the synchronous one. Basically, the asynchronous generators will generate electricity when working in parallel to the electrical grid supplying the reactive power necessary for magnetisation (magnetising current). The standalone operation of an asynchronous generator is possible, but requires applying additional systems allowing for exciting of the machine and stabilising the voltage and frequency.



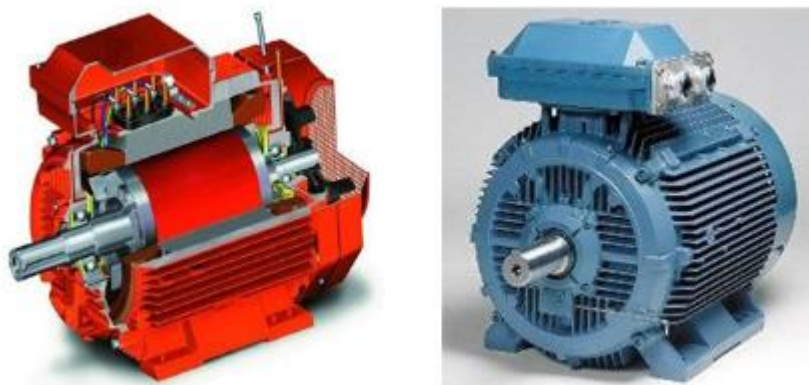

**Figure 55: Asynchronous generator (Little, 2016)**

Among the asynchronous generator advantages one should count its simple design and low cost. The disadvantages include incapability of standalone operation (island operation requires employing of specialised auxiliary systems) and the need of reactive power compensation. Additional drawback is the necessity to use a speed increaser allowing for mechanical power transfer from the hydraulic turbine shaft to that of the generator.

### 3.3.4 Synchronous permanent magnet generators

The stator of permanent magnet synchronous generators is generally manufactured as a three-phase winding whereas the exciting winding is replaced by permanent magnets. In this kind of machines the generated voltage and frequency values depend on rotation speed.

High efficiency in a wide range of rotation speeds is to be counted as a significant advantage. The disadvantages include relatively high cost and the need to use electronic power conversion systems allowing for parallel operation with the grid.

## 3.4 Electronic power conversion systems

The power electronics systems are of ever higher significance in the electric power engineering. Initially, application of power conversion systems was limited to using uncontrolled rectifiers in the feeding systems of DC devices or to charging accumulators representing an electricity supply reserve. The next step was employing controlled rectifiers in the excitation systems. Development of power electronics and electronic control systems resulted eventually in gradual replacement of the traditional rotating machinery based excitation systems by static ones.

Today, the use of electronic power conversion systems to control the hydraulic unit rotation speed is an ever more frequent practice. Speed regulation by means power conversion systems is based on relevant control of the unit load. For this purpose use is made of the AC/AC converters with generator side voltage and frequency matched to the power grid parameters. At the same time the converters provide generator load control in a manner ensuring the optimum unit operation. The IGBT transistors are most frequently used as semiconductor power components in the high power converter systems (Figure 56).

The use of power conversion systems allows on the one hand eliminating the mechanical gear and on the other one - enables variable speed operation of the hydraulic machine which results in better use of the hydropower resources (operation with optimum speed which is of particular significance for single regulation turbines). Furthermore, the power conversion systems are a necessary equipment of units with permanent magnet synchronous generators which voltage and frequency depend on the rotation speed. Both have to be matched to the power grid parameters at the grid connection point.

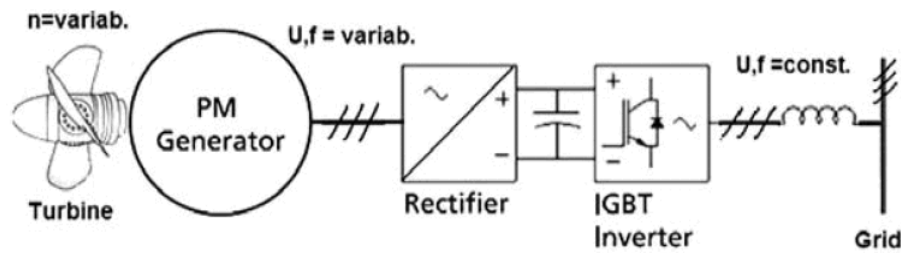

Figure 56: Schematic of a power electronics unit with a thyristor or an active IGBT rectifier and an IGBT inverter (Sobczyk et al., 2010)

### 3.5 Further electrical equipment and control systems

Running a hydroelectric power plant requires appropriate electrical equipment, starting from generators through auxiliary equipment and transmission lines. Generators convert mechanical energy into electric one which is transmitted afterwards to the receivers via electric transmission lines. Transmission lines are developed as overhead and underground ones. The so called sub-hanged lines – with a transmission cable hanged at the electrical poles. In order to lower the transmission losses transmission lines are erected for voltages higher than that of the generator. In such cases transformers enabling matching the voltage generated by the unit to that of the electrical grid are necessary. Furthermore, transmission of electrical energy requires auxiliary equipment and switchgears. The auxiliary equipment includes the devices that are necessary for power plant operation, but don't take part in the process of electricity generation – e.g. oil or dewatering pump engines. The switchgears allow proper distribution electricity onto individual circuits and electrical system operation (connecting activities). The electric equipment includes also measurement instrumentation as well as protection and control devices.

Electricity generation requires proper control of all devices taking part in this process. Currently, the staff is supported by relevant control systems facilitating power plant operation. The widely conceived control system consists of measurement instrumentation as well as protective and control devices. Interaction with the staff/user is also enabled. Finally, the appropriately developed control systems allow unmanned power plant operation and/or remote control. Integration of all above-mentioned tasks contributes to facilitating the staff work, increasing the electricity supply safety and decreasing the operational costs – e.g. by introducing the predictive maintenance and diagnostics components preventing major failures.

The contemporary control systems are usually featured by multilevel structure - that is the individual devices are furnished with dedicated control systems (e.g. turbine governor) which are incorporated into the control system of equipment groups (e.g. block controller) and then into the power plant supervisory control system.

The PLC controllers are of substantial significance in the control systems. The controllers are furnished with appropriately selected set of analog and digital inputs and outputs and allow data transmission between the devices. Ever more frequently the control systems of individual devices are also furnished with operator panels allowing monitoring or changing their operating parameters.

Visualisation and control of power plant operation are generally conducted from the level of operator station connected to the supervisory control system. Generally, the system allows monitoring the condition of the equipment and their technical parameters as displayed in the technological schematics (Figure 57). The system tasks include also reporting current events, such as surpassing the alarm or trip values, recording the events and parameters, survey of archived records. Typical examples are shown in form of screen shots taken from a control and supervision system in one of Polish hydropower plants furnished with 2 Kaplan and 1 Francis turbine units.

The violet, green and yellow panels in Figure 57 denote start-up, shutdown, and emergency shutdown, respectively. The isle operation start-up panel can be seen additionally in case of unit 2. Improper pressure in the spiral case immediately after shutdown is shown in red in Figure 58.

The general trend is to perform most of activities in an automatic mode, after occurrence and fulfillment of some specific requirements. For instance, the start-up process should be preceded by attaining the state of start-up readiness (including no safeguard excitation). Next, the operator issues the start-up command. After this time point the consecutive steps of the start-up procedure are performed with each subsequent step commenced only after the necessary conditions are fulfilled (e.g. the required speed is reached prior the synchronization process starts). Any disturbance in the unit operation or the sequence course is reported to the operator (with the problem source indicated) and the system undertakes the activity adequate to the situation having occurred.

The essential component of the generally conceived control system are protection devices which task is to take care of safe operation of the equipment, to minimise probability of a failure and minimisation of their consequences. In contrary to the previous situation in the electrical power protection automation with individual protective functions ascribed to separate devices, the contemporary market is dominated by digital devices fulfilling a number of protective functions which allow the user configuring their parameters by means of the relevant software. For instance, the respective list of generator safeguards includes among others the over current, ground-fault, under and over frequency, over and under voltage, reverse power protection. In addition to the complex protection they provide also communication with the supervisory monitoring and control systems and deliver the measurement data. In case of hydromechanical part the protective function (e.g. against temperature, too high or too low oil level) is fulfilled by controllers of separate devices or the supervisory system.

In order to increase the electricity generation reliability, lower the operational costs and improve the staff work comfort the control systems are subject to continuous development. Their stage of advancement and complexity is demonstrated by the number of process variables in a hydraulic unit control system, often as high as several hundred. Of course, the unsupported staff would be unable to monitor such a number of parameters. The computerised monitoring systems facilitate the faultless power plant operation preventing the operator from actions not allowed in a given situation. The significance of automatic control systems for power plant safety and faultless power plant operation can be easily demonstrated at an example of synchronisation process which can lead to severe consequences if improperly conducted. The proper "manual" synchronisation has always required substantial expertise. Today, even the first synchronisation (during unit commissioning) is often conducted by means of an automatic synchroniser, as this technique is considered a more safe solution. The control systems allow automatic regulation of the hydraulic unit/power plant/electrical grid operating parameters such as water level, power and voltage. Contemporary control systems allow also increasing the use of hydropower potential and decreasing the electricity generation operational costs by introducing control algorithms taking care of the optimum running of devices.

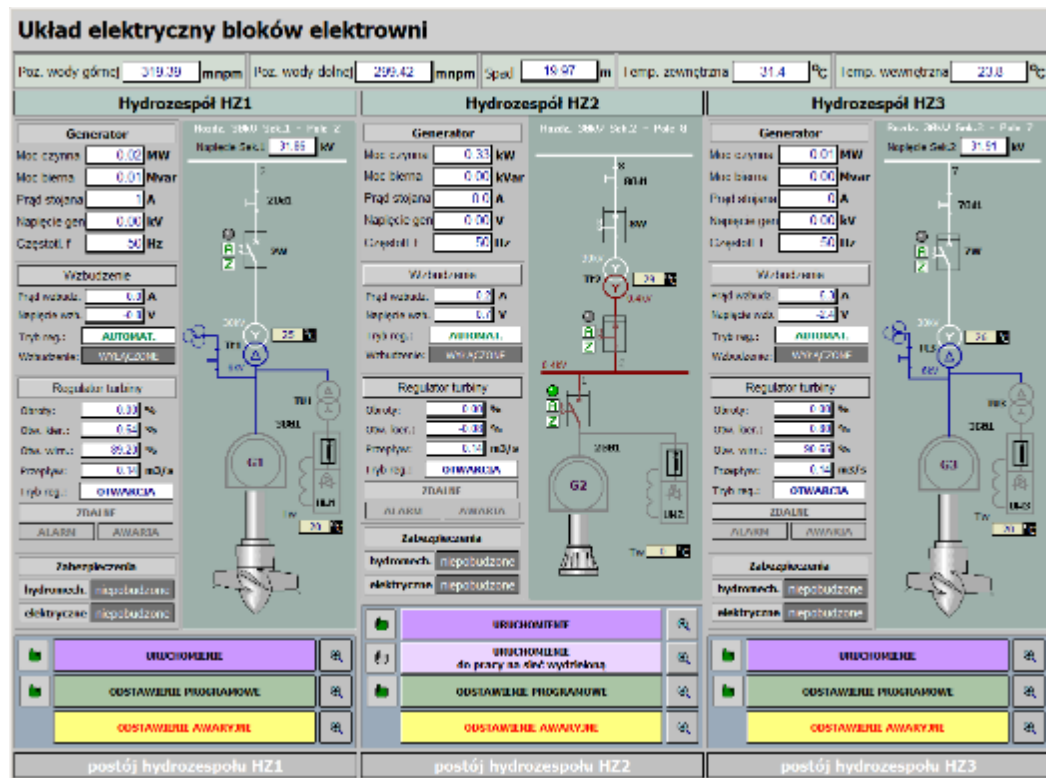

Figure 57: Electrical system schematic of an SHP power blocks in Southern Poland. A screenshot taken at standstill from the power plant supervision and control system (Courtesy of PGE EO SA)

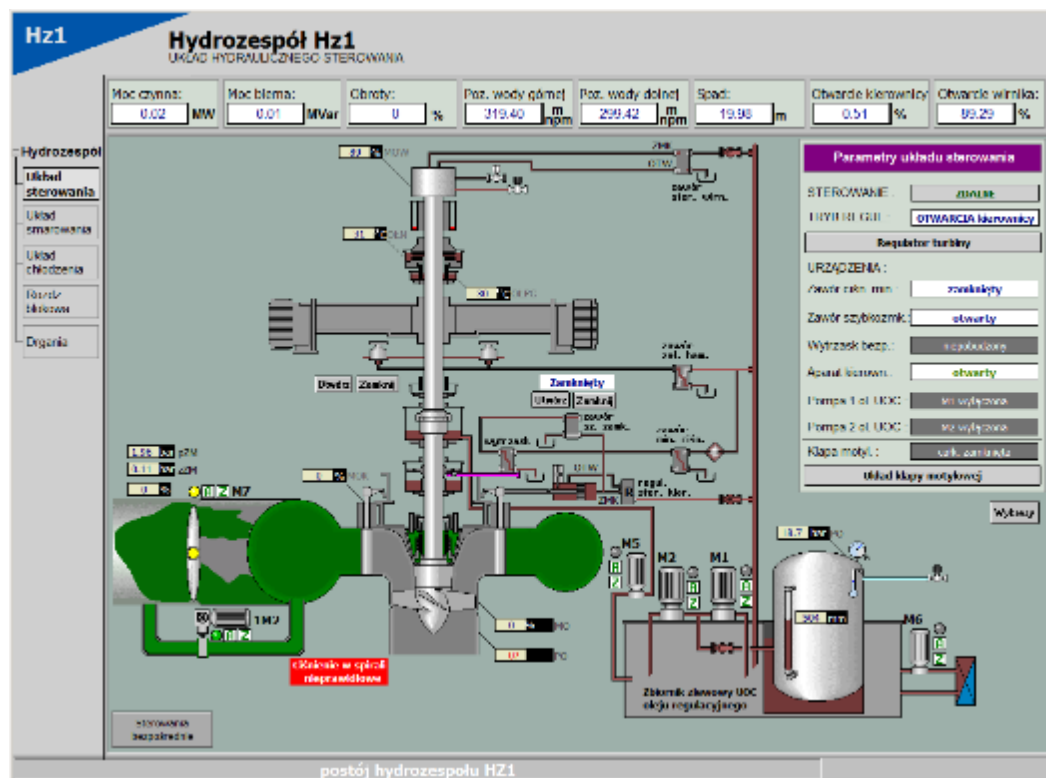

Figure 58: Unit 1 hydraulic control system schematic of an SHP of Figure 53. A screenshot taken immediately after shutdown from the power plant supervision and control system (Courtesy of PGE EO SA)

## 3.6 Hydromechanical steel works

The process of mechanical energy conversion into electricity in a classic (non-hydrokinetic) hydropower plant starts at the water intake and ends in the tailrace. Irrespective of the civil engineering infrastructures, a significant progress having taken place in the hydropower technology over recent decades covers not only hydraulic units, but also such mechanical devices as:

- trashracks and trashrack cleaners;
- intake and spillway gates;
- penstocks;
- hydraulic turbine inlet valves.

Additionally, various arrangements discouraging the fish from coming in contact with trashracks and entering the intake are used at the headrace. Whenever possible their task is to guide the fish to the downstream migration facilities.

### 3.6.1 Floating booms and trash racks

The inlet to modern hydropower plants is often protected by 2 or 3 stages of mechanical arrangements:

1. floating booms which can stop floating debris and guide large floating bodies, such as tree trunks, away from the power plant forebay;
2. primary and secondary trash racks preventing debris of various size from entering the turbine

Contemporary floating booms are ever more frequently manufactured out of plastics or composite materials linking low weight with high mechanical strength and lack of corrosion risk. Typically they are anchored to riverbed or to a dedicated bridge. Sometimes a debris trap is included into their configuration. The market is heavily dominated by patented US and Canada products, such as Tuffboom by Worthington and Elastec. However, the technology is widely used also in Europe. Some European companies, offer also alternative products for small scale installations, such as inflatable booms (Bolina Booms, 2020).

Trash racks (inlet screens) are usually fabricated out of stainless steel and occasionally also plastic bars. The typical structure consists of a series of bars of nearly rectangular cross section linked by connecting rods. Typically, the trash rack screen plane is deviated by less than  $30^\circ$  from the vertical one. The fine trash rack bar spacing varies from a clear width of 12 mm for small high head Pelton turbines to a maximum of 150 mm for large propeller turbines (ESHA, 2004). Spacing up to 100 mm or even more is encountered in case of primary trash racks. The fine trash rack bar spacing is often a result of a compromise between the environmental requirements (see section 3.7) and the plant operator's wish to avoid excessive hydraulic losses. The hydraulic losses of clean trash racks can be estimated using the formulae available in most relevant textbooks. In numerous contemporary installations an increase in trash rack losses as measured by difference of water levels activates the automatic trash rack cleaners.

Generally, trash racks are mounted in segments allowing easy dismantling for the repair or replacement purposes. Due care has to be taken to avoid vibration stimulated for instance by the von Karman vortices or pressure fluctuations in the turbine flow system.

In most mini hydropower plants trash racks are equipped with trash rack cleaners which can represent various design and operation principles. Basically, both mobile and stationary devices are in use, depending on the number of units. The electrically driven wire rope and chain devices are still encountered in large and quite small plants, respectively. The wire rope devices are often furnished with grab rakes allowing to taking off debris even from direct neighbourhood of the rack. Hydraulically driven telescopic and articulated cleaners are more typical for most modern mini and small hydropower installations (Figure 59). The offer of European manufacturers is quite abundant and showing numerous innovative design solutions.

In case of some small hydro installations the drop intakes (e.g. the Tyrolean inlet) with self-cleaning horizontal or nearly horizontal trash racks are also in use. An interesting example is the Coanda screen consisting of a series of wedged section wires (Figure 60) and using the effect of water stream adhesion to the flown around solid surface. The advantage of such a design is easy downstream transportation of any debris or gravel and avoidance of any harm to fish which just slides over the curved Coanda screen surface towards the stream bed fed with residual flow. Due to substantial hydraulic losses both Tyrolean type and Coanda inlets are used mainly in high head schemes in Alpine countries.

More information about racks is provided in subchapter 3.7.3.



Figure 59: Articulated trash rack cleaner in Januszkowice SHP - Oder river, Poland (source: J. Steller)

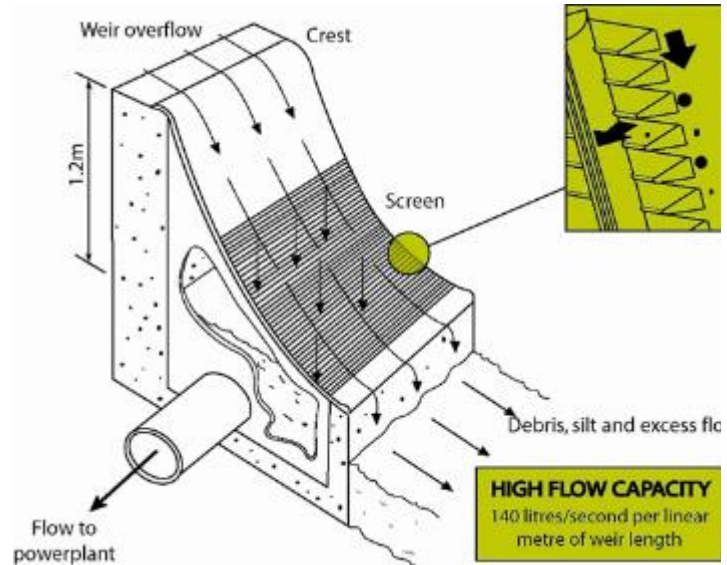

Figure 60: Aquashear Coanda screen (Dulas Ltd, 2020)

### 3.6.2 Intake and spillway gates

The vertical lift slide or wheeled gates made usually of cast iron, steel or timber boards are the most typical shut-off devices at water intakes to numerous hydropower plant flow systems (ESHA, 2004). Their main tasks can be summarized as follows:

1. to stop water flow in emergency situations
2. to enable dewatering of the power plant flow system
3. to enable controlled watering of the power plant flow system

Sometimes the vertical lift gates are located also at the draft tube outlets. In modern small hydropower plants the gates are often hydraulically driven and controlled by the supervisory power plant control system. Electrically driven wheeled and caterpillar vertical lift gates are encountered in some large and older small installations. The use of manually driven ones is highly limited nowadays and concerns mainly the spillways. In low head installations the function of an emergency shut-off device can be taken over by an inlet valve or even by the turbine wicket gates alone. The vertical lift gates (Figure 61) are used mainly for dewatering purposes and can play the function of maintenance stoplogs. However, in installation of higher capacity and/or head the watering always starts and is conducted for a longer time with using the by-pass conduits in the water intake structure.

On the other hand, in medium and high head installations with long pressurized penstocks the swift closing (emergency) intake gates are often a measure of key significance in the chain of various power plant safe-guards.

However, exactly in this case it is also essential that all the closing devices – intake gate, turbine inlet valve and wicket gates or needle nozzle - are used in proper sequence and with prescribed speed so as to minimise dangerous consequences of load rejection and resulting hydraulic transients.

The headrace water pressure is usually capable to improve the intake gate tightness. Nevertheless, this measure may be regarded insufficient for avoiding substantial leakage and conducting major overhaul works inside the installation flow system. Double closing with no possibility of incidental opening may be considered also essential out of safety reasons. Therefore intake locks are generally furnished with overhaul stoplog hollows situated in the intake sidewalls directly upstream the vertical lift gates if any. Timber beams or boards are generally used as stoplogs in small installations.



**Figure 61: The Rutki SHP water intake - Radunia Cascade, Poland (source IMP PAN archives)**

In addition to the vertical slide or wheeled gates, also radial and cylinder gates as well as butterfly valves are used at hydropower plant water intakes (Daniel and Paulus, 2019). Figure 62 shows a cylindrical gate application at inlet of small submersible axial flow turbines. However similar arrangement is used also at vertical water intakes to some large storage hydropower plants.

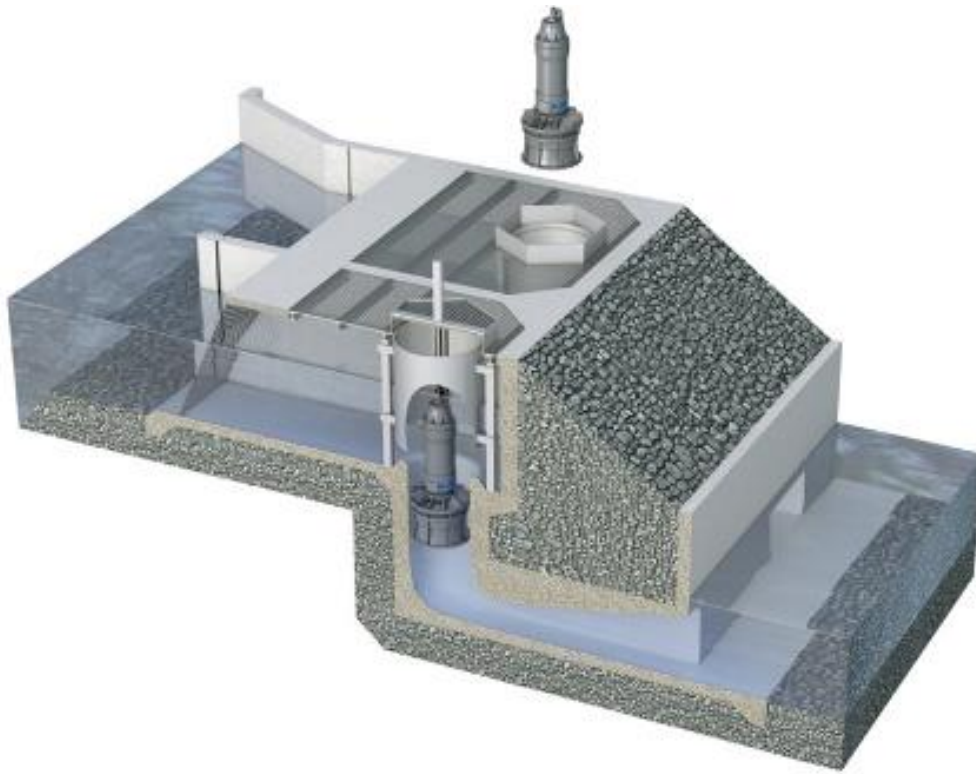

**Figure 62: A small hydropower plant with two submersible Flygt and cylindrical intake gates (Flygt, 2020)**

Most hydropower dams are furnished both with gated and non-gated spillways. While the first ones can be used for various purposes linked with discharge and/or water level control, the principal task of the immobile spillways is to protect the dam and other related structures or equipment against damage due to uncontrolled water overflow through the dam crest. Also in case the gated spillway shows too low capacity or is no more controllable. Therefore the non-gated spillways are usually erected as overflow (chute) ones with waterway bed at specially shaped portion of the dam slope and/or a by-pass canal. The so called “Morning Glory” vertical shaft spillways with tunnels delivering water downstream the dam are also in use.

Regulated spillway gates are used in various versions: In addition to the vertical lift (slide, wheeled) gates which can be used both in small and large installations, flap, roller, drum, roof and especially radial gates are in use (Daniel and Paulus, 2019). The radial gates can be hinged to pillars (pin type support) between the weir segments or to the wear sill (linear support). The pillar hinged radial gates are often named segment or Tainter gates after the name of their inventor whereas sector gates are generally hinged to the weir sill. Sector gates can be usually hidden in the sill bed when the gate is open. Schematic of a typical Tainter gate located over an overflow spillway at so called ogee weir is shown in Figure 63.



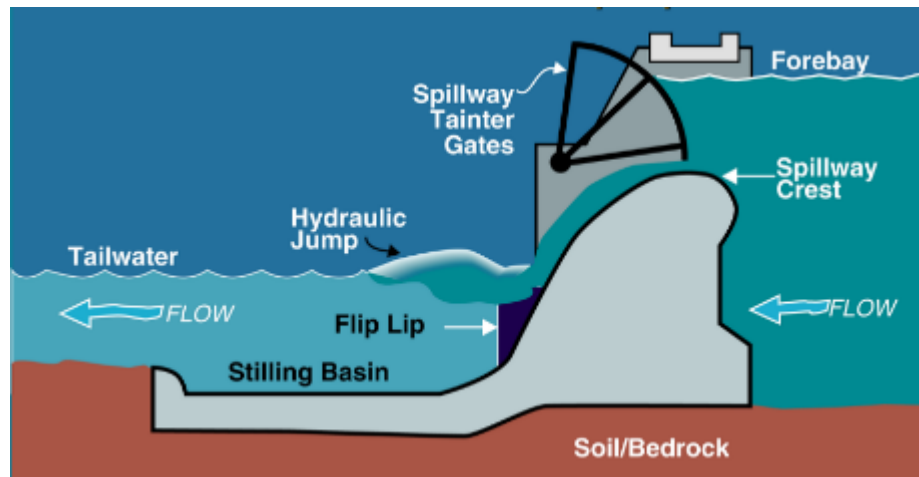

Figure 63: Segment (Tainter) gate (USACE, n.d.)

Flap gates are traditionally widely used in numerous low head applications. Figure 64 shows a typical crest hinged version. However, some other configurations, including flaps hinged to the abutment and to a Tainter gate skin plate edge are also in wide use (Figure 65).



Figure 64: Weir crest hinged flap gate at Rzeczyca SHP - Wierzyca river, Poland (source: J. Steller)

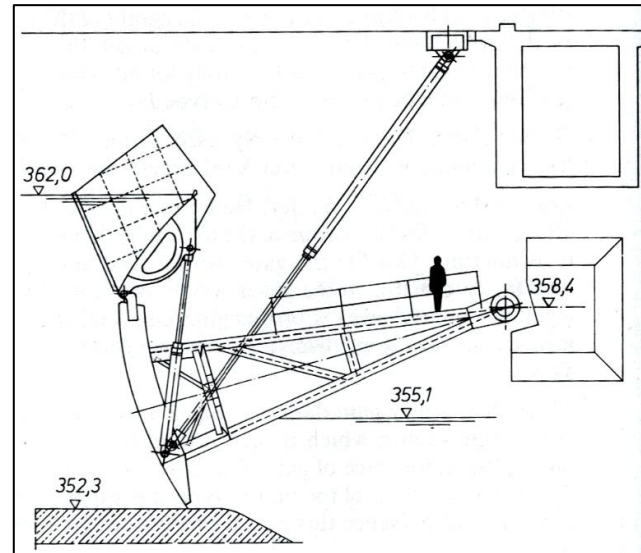

Figure 65: Fish belly flap hinged to a Tainter gate edge. Perach HPP - Inn river, Germany (Raabe,1985)

Inflatable weirs are flexible gates in the form of a reinforced, sheet-rubber bladder inflated by air or water, anchored to a concrete foundation by anchor bolts embedded into the foundation. Like any other gate, the inflatable weir needs a mechanism by which it is opened and closed. The weir is raised when filled with water or air under pressure. An air compressor or a water pump is connected, via a pipe, to the rubber bladder. When the bladder is filled the gate is raised; when it is deflated the weir lies flat on its foundation, in a fully opened position (Figure 66, left). The system becomes competitive to traditional flap gates when the width of the weir is large in relation to the height (ESHA, 2004).

Although originally developed and patented in the US by the companies Flexidam–Imbertson, Firestone and Bridgestone as early as the 1950s to the 1960s, inflatable weirs came to wider use in Europe only in the 1980s. At this time point an alternative version – with an inflated bladder or a set of bladders supporting a row of steel plate flashboards (Figure 66, right) – was patented by the US based Obermeyer Inc. company which still remains a leading supplier of this kind of equipment. Today the inflatable weirs are manufactured worldwide with Dyrhoff

Ltd and Rubena (Trelleborg Bohemia) keeping the leading role in Europe. While typical damming height does not exceed 3 to 4 m, weirs with a height over 8 m are also encountered in inland navigation routes.

The inflatable weir bladders are generally manufactured out of a multilayer composite consisting of rubber with polyamide and polyester material. The polyamide material is generally responsible for necessary tensile strength whereas the external rubber increases resilience to UV radiation as well as resistance to slurry erosion and possible freezing of floe plates in winter season (Figure 67).

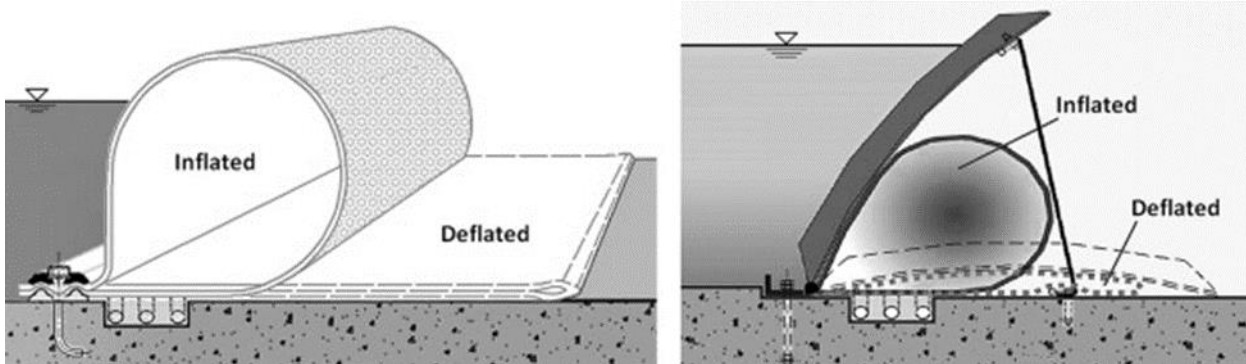

Figure 66: Inflated weir principle of operation (Daniel & Paulus, 2019)



Figure 67: Inflatable weir in winter and summer seasons, Kliczkow SHP - Kwisa river, Poland (Polniak, 2015)

As already mentioned, avoiding consequences of uncontrolled water overflow through the dam crest requires rapid increase of spilling discharge in response to the flood water surge even if the regulated gates are already completely open or no more controllable. For this purpose overflow spillways are often furnished with special arrangements allowing for much higher spilling discharge than that of a typical immobile weir. Generally, the goal is achieved by elongating the spillway crest or by lowering its elevation. The first measure is effected by shaping the crest in a labyrinth form. Lowering crest elevation is achieved by using bear trap gates, siphon arrangements, fuse gates and spring weirs. Their great advantage is high spilling discharge immediately after the critical water level has been surpassed (ESHA, 2004). Furthermore, in case of some techniques a hysteresis phenomenon occurs, as spilling ends only after water has fallen well below the level at which it has started.

Figure 68 shows the schematic of a traditional fuse gate as designed by a French company Hydroplus. There is no spilling until the maximum allowable damming level is reached. Once it happens, the fusegate box swings away from the original position and intense spilling starts. A number of other designs based on similar principle are commercially available now as well.

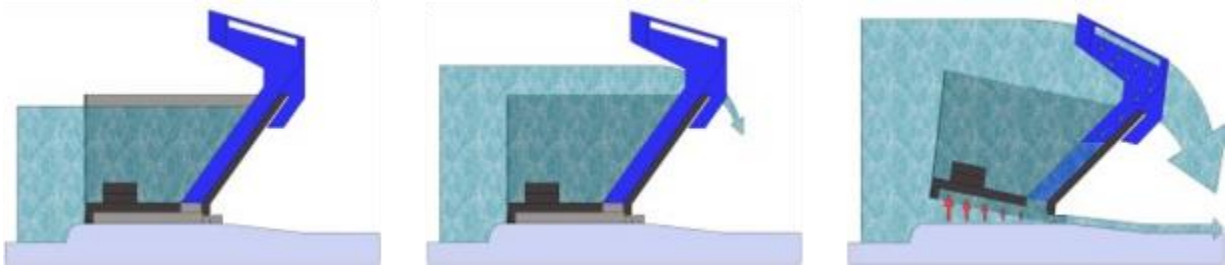

**Figure 68: Hydroplus classic fuse gate. Principle of operation (Hydroplus, 2020)**

An even more simple and highly elegant design is represented by the so called spring weir as offered by Wiegand. The main component of the arrangement is an elastic plate mounted at the existing weir crest and deflecting under the weight of dammed water (Figure 69). The key issue is material quality which should show at the same time high elasticity, very high yield strength and high resilience to harsh environmental conditions. According to Wiegand, increasing the allowable damming level by even 70 cm above that of the original weir is possible. However, only low and very low head applications are known so far.

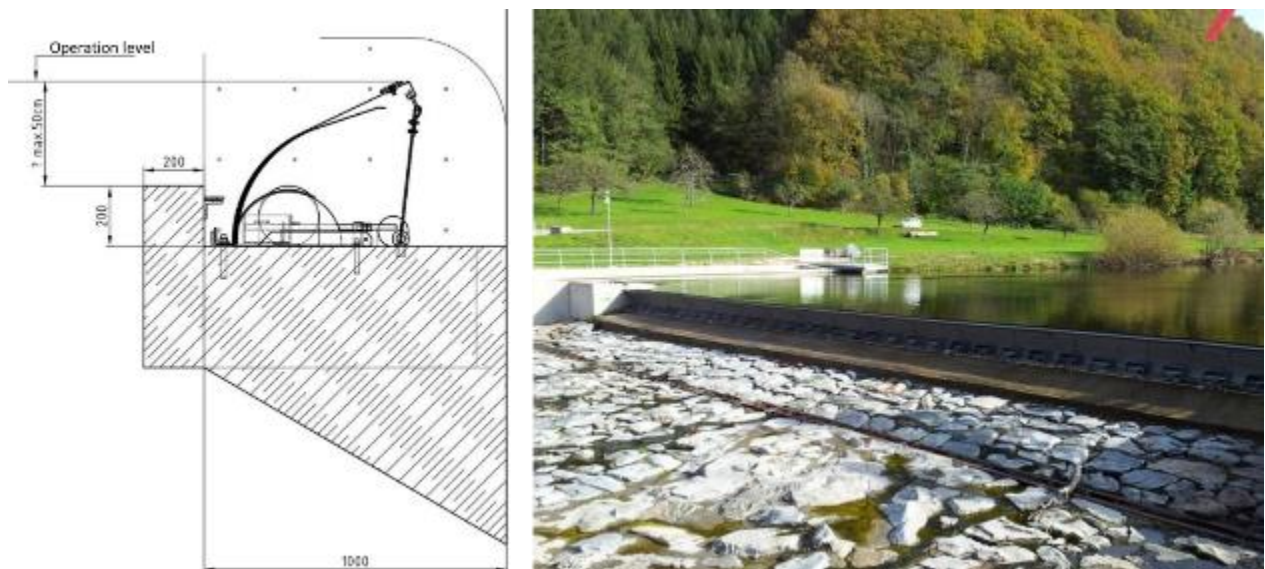
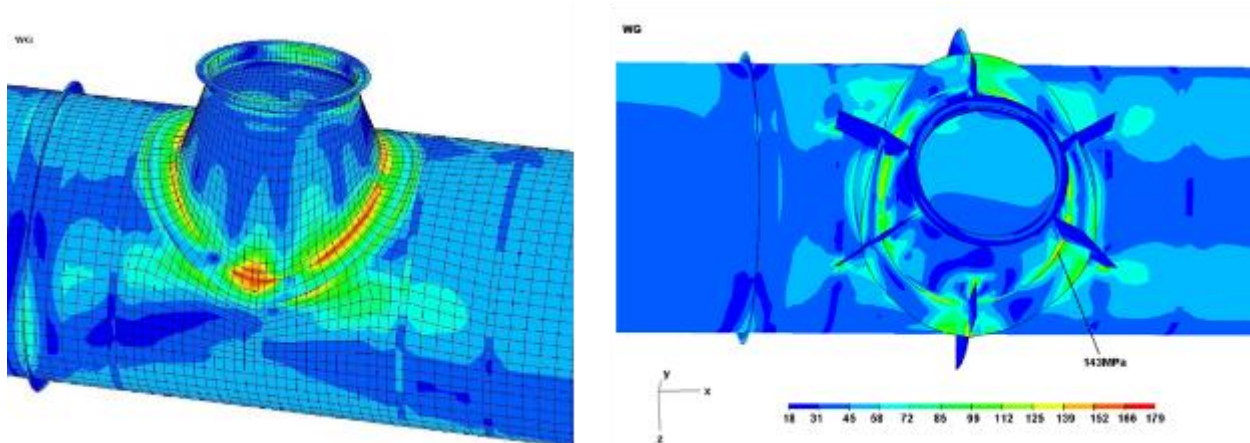

**Figure 69: A spring weir principle of operation and existing installation at Hausach - Kinzig, Germany (Wiegand, 2020)**

### 3.6.3 Penstocks

Penstocks are pressurized conduits delivering water to the turbine. The penstock material and technology may be quite diverse, depending on the head, discharge and locally available resources. Generally, fabricated on-site welded steel tubing is used for the larger discharges and diameters. Proper selection of material and welding procedure as well as experienced welders are needed in order to minimise the welded joint imperfections leading to increased local stress and strain, occurring especially during hydraulic transients accompanying hydraulic unit(s) start-ups, shut-downs and load rejections. While some minor inflections may extinct in time due to plastic deformation, due attention must be attributed to all such sites. Due to lower price and high welding process repeatability spiral machine-welded steel pipes can be considered a reasonable option if they are available in the required sizes. The contemporary welding procedure includes generally a thorough diagnostic test of the weld quality. In case of large and some older penstocks assessments of residual lifetime, based also on the wall thickness and stress measurements, are repeated in the course of exploitation. Fatigue aspects linked with the number of transient phenomena are always included in the analysis.

When assessing the welded penstock system quality, particular attention has to be paid to possible bifurcations and other branching structural nodes which may require additional stress relief arrangements. The finite element method (FEM) based solid structure analysis software is used nowadays together with that of hydraulic transients analysis to assess the expected stress and to select the most appropriate stress relief measures (Figure 70). In case of straight penstock segments these can include also pre-stress introduction by means of penstock band-ages. The mentioned computational tools are in direct and indirect use by practically all relevant design offices in Europe.



**Figure 70: Tensile effort ( $\text{MN/m}^2$ ) distribution at penstock branching node (Adamkowski et al, 2019)**

For smaller diameters one can choose between manufactured steel or ductile iron pipes, ever more competitive plastic tubes and the spun or reinforced cement concrete (RCC) ones. In some developing countries pressure creosoted wood-stave, steel-banded pipes are considered an alternative.

In case of steel and ductile iron pipes the  $H/Q^{1/3}$  ratio is used sometimes as a material selection parameter (Figure 71). The manufactured steel pipe are supplied with spigot and socket joints and rubber "O" gaskets, which eliminates field welding, or with welded-on flanges, bolted on site. The most typical penstock joints are shown in Figure 72. The gland, flange or push-in socket joints introduce a sort of dilatation necessary to survive safely variable mechanical and thermal loads. Flange joints are generally used whenever a device requiring possible dismantling – e.g. turbine inlet valve - is to be connected whereas expansion joints are in use at connections with stiff installation members, such as anchor blocks and turbine distributor.

Recent decades have seen also further rise of a competitive offer of penstocks and penstock linings made of such materials as glass reinforced plastics (GRP), glass and carbon fiber reinforced plastics (GFRP and CFRP, respectively) and high density polyethylene (HDPE). Replacing some previously offered plastics, such as PVC (polyvinyl chloride) or PE (polyethylene), is linked with higher functional properties shown by the newly introduced materials. The most important advantages include low hydraulic losses, low maintenance costs due to no corrosion risk and low pressure wave celerity leading to lower water hammer pressure surges. The suppliers claim also high mechanical strength parameters and resistance to abrasive erosion as well as other environmental impacts, such as UV radiation. The maximum available diameter is 4,000 mm width.

There key worldwide supplier of the GRP penstocks is the Amiblu holding with headquarters in Klagenfurt, Austria, and production facilities in Germany, Spain, Poland and Romania. Amiblu combines Amiantit Europe and its Flowtite Technology, and Hobas Europe, part of WIG Wietersdorfer Holding. The Flowtite pipes are built as a structural sandwich, using a continuous filament winding technology. The high-strength continuous glassfibers resist the hoop stresses from internal pressure, while the chopped fibers provide excellent resistance to axial stresses, impact, and handling loads. The structural laminate consists of heavily reinforced skins, separated by a compact, reinforced silica-filled core to provide optimal bending stiffness (**Fehler! Verweisquelle konnte nicht**

gefunden werden.). An alternative, centrifugal casting technology is used by Hobas. The manufacturing machine's arm feeds all raw materials – chopped glass fibers, thermosetting plastics (unsaturated polyester or vinyl ester resins), and reinforcing agents – into a fast-rotating mold. Layer by layer, in a predefined process, the pipe wall is built up from the outside inward (Amiblu, 2020).

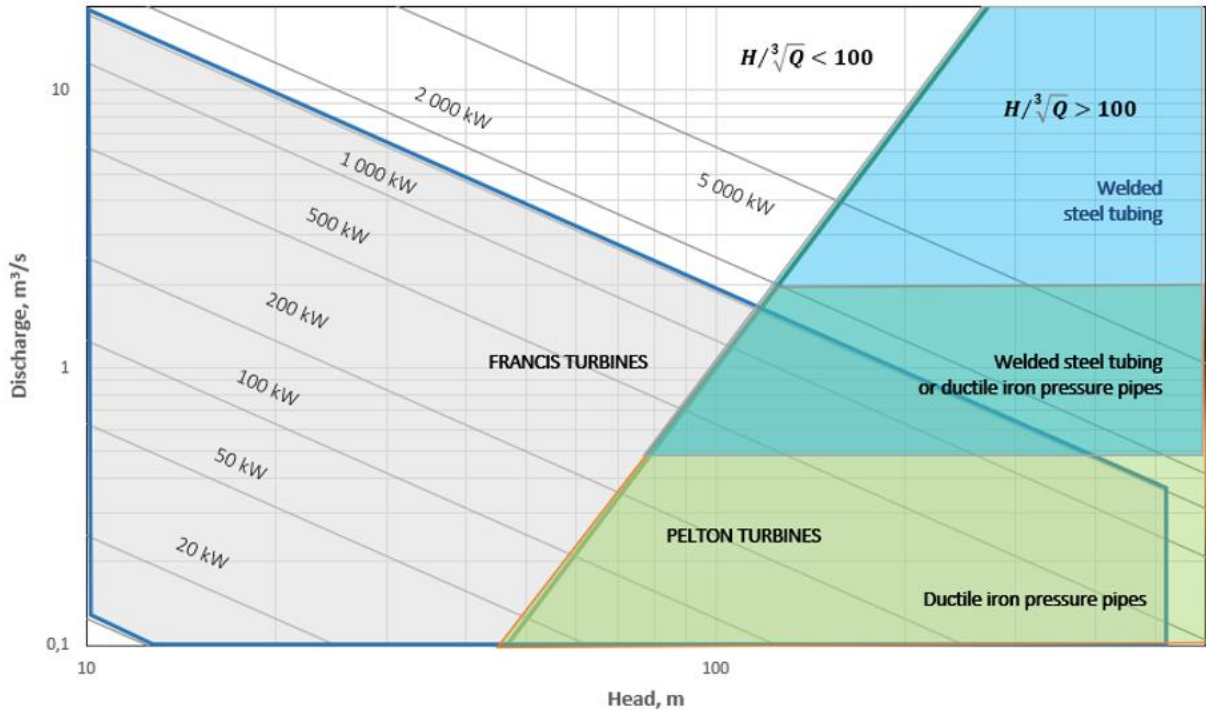

Figure 71: Typical steel and ductile iron penstock small hydro application ranges (Steller, 2020 after anon)

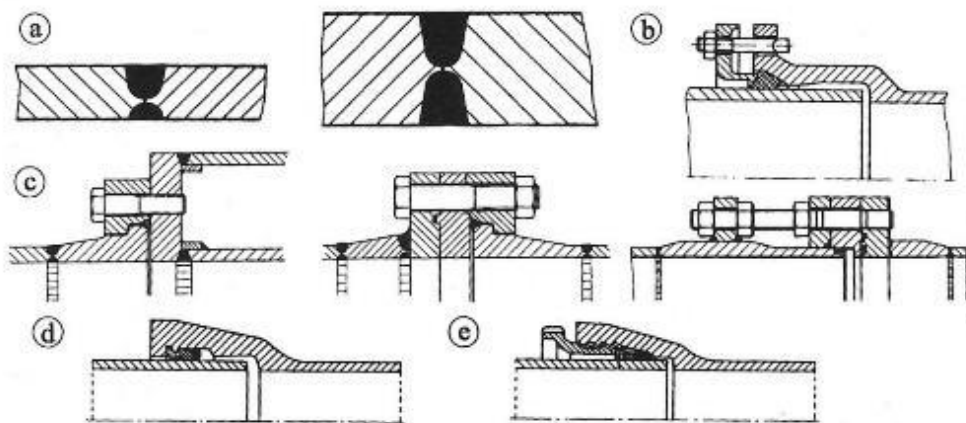

Figure 72: Typical steel and ductile iron penstock joints: a) welded joints; b) gland joints; c) flange joints; d) spigot joints; e) threaded spigot joints (Giesecke & Mosonyi, 1998)

The GRP penstocks are ever more widely used both in new installations and the rehabilitated ones. Sometimes as a replacement following the previous penstock failure (Figure 73). Among most significant GRP hydropower penstocks one may count those in Schwarzach HPP (head 264 m, penstock length 4.3 km, planned uprating to 16.9 MW, Austria) and Feldsee Pumped Storage Power Plant (head 524 m, 70 MW, Austria). In the last case the Flowtite piping is used as lining in rock tunnel.



**Figure 73: Flowtite pipe structure (left) and replacement of a wood stave penstock segment by a Hobas GRP pipeline (right). Jackman Hydro Station, Hills-borough, New Hampshire, USA (Amiblu, 2020)**

With exception of largest diameters and in case of sufficiently stable geotechnical conditions, buried penstocks are often recommended, provided there is only a minimum of rock excavation required. Expansion joints and concrete anchors can be thus eliminated as the sand gravel backfill provides natural insulation. Maintenance painting and anticorrosive wrapping is not required, although protective measures are of essential significance at the installation stage (Gordon & Murray, 1985). In case the surface penstock option has been selected, proper design and reliable foundation of penstock anchor blocks and supports are of crucial significance for penstock safety. Their fundamental role in dissipating the pressure fluctuation energy during hydraulic transients is hard to be overestimated. In fact, irrespective of such factors as support failure or shift due to landslides or earthquakes, the basic threat to penstock safety comes from repeated water hammer phenomenon accompanying start-ups and shutdowns, and especially emergency shutdowns and load rejections. The inertial pressure rise or fall resulting out liquid column deceleration or acceleration can be evaluated from the second principle of dynamics as

$$\Delta p = -\frac{\rho}{A} \frac{dQ}{dt}$$

with  $\rho$ ,  $A$  and  $Q$  standing for liquid density, penstock cross-sectional area and discharge. In fact the equation is the basis for deriving the pressure-time discharge measurement (Gibson) method. The purely inertial model assumes liquid incompressibility (infinite sound speed) and leads to infinite pressure rise in case of a sudden liquid column stoppage. Arriving at a physically justified value requires including water compressibility into considerations which was done already in the end of the 19th century.

According to the N. Joukovsky formula, the maximum pressure rise due to a sudden liquid column stoppage is

$$\Delta p_{\max} = -\rho c \Delta Q / A$$

with  $c$  standing for sound celerity. The formula is considered valid in case the closing process duration is shorter than the pressure wave reflection time. Otherwise inertial and pressure wave interference effects have to be accounted for. These and other hydraulic transient aspects – including water column separation – are duly included in most modern software packages used nowadays by relevant design and consulting offices as well as

collaboration research and development institutes. In case of hydroelectric power plants with reactive turbines, including the so called 4-quadrant turbine characteristics and the wicket gate closure law as one of boundary conditions, is of key significance for reliable prediction of both hydraulic transients within the penstock and the rise of hydraulic unit rotation speed after grid connection has been switched off. Applying the optimized wicket gate closing law is a key operational measure used to mitigate unwanted consequences of swift shutdown processes (so called valve stroking method).

Steps towards mitigating the hydraulic transient effects are undertaken also by the designer of the diversion scheme which in addition to the penstock can include also a free surface diversion canal and/or a pressurised tunnel with steel or concrete lining. The main civil engineering arrangement mitigating hydraulic transients is a surge tower used to attenuate the increased pressure wave and to dissipate its energy.

### 3.6.4 Hydraulic turbine inlet valves

Gates and valves can be encountered at various sites of a hydropower installation flow system, including water intake, turbine inlet, inlet to the water relief conduits. Aeration valves are occasionally included in a hydraulic turbine equipment – used during normal operation (e.g. classic cross-flow turbines), at the end of the turbine shutdown or just to stop a turbine in siphon configuration.

Numerous low head turbines, especially Kaplan ones - both those with semi-spiral casing and those in tubular configuration – use their vertical lift inlet gates as their only cut-off devices, often excluded from the emergency shutdown procedures. In case water is delivered by a penstock, inlet valves are mounted at the distributor entrance allowing thus turbine flow system isolation from the inlet installation.

Although wedge shaped stoppers are still in use in some installations, butterfly, rotary and globe valves (Figure 74 and Figure 75) are generally used at inlets to turbine distributors. Hydraulic actuators are usually in use in modern and larger installations. In case of high heads (> 200 m) using pressurised (head) water instead of oil is recommended. Counterweights are used in order to diminish the effort required for closing and to allow self-closing in case of emergency.

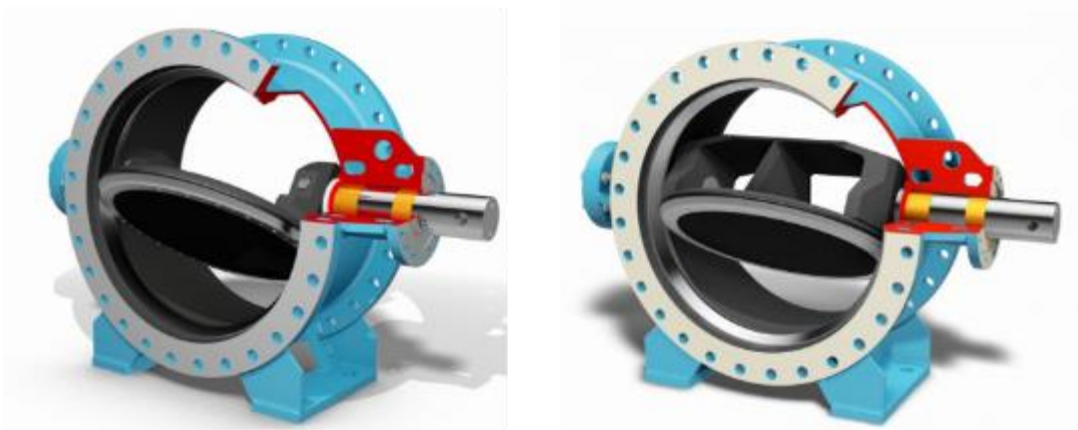

Figure 74: Butterfly valves as offered by the TB Hydro company (TB Hydro, 2020)

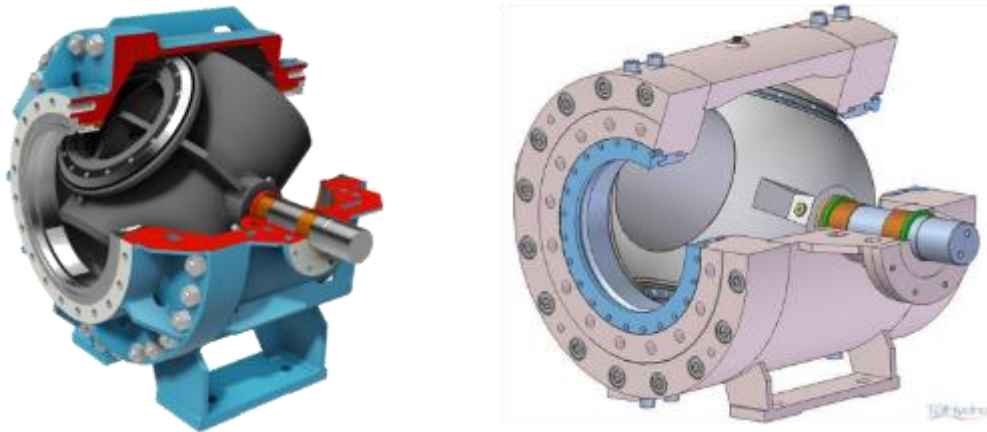

Figure 75: Rotary and globe valves as offered by the TB Hydro company (TB Hydro, 2020)

### 3.7 Fish Passage Measures

Subchapter 3.7 is a contribution from the FITHydro consortium (project coordinator: Peter Rutschmann). This text uses original contents of the FITHydro Deliverable 2.1, authored by: Laurent David, Manon Dewitte, Dominique Courret, Sylvain Richard, Pierre Sagnes. Modifications of the original D2.1 contents were made by Peter Rutschmann.

#### Preface

This contribution originates from the FITHydro project deliverable 2.1. It is similarly structured as the original and the content is often overtaken without changes. The work and the ideas described in D2.1 are the product of contributions of many people from the 26 partners in FITHydro. In many parts the text of D2.1 is shortened and design guidelines are not included. Readers interested in detailed information should therefore study the original deliverable at <https://www.fithydro.eu/deliverables-tech/>.

#### 3.7.1 Introduction to fish upstream and downstream migration

Many fish migrate hundreds of kilometers between their habitat and their spawning grounds. Typical examples of such migrations are the salmon or eel, which have to migrate between the sea and the river. If their migration is hindered or made impossible, reproduction is not possible. Other fish need such migrations as well, but in a smaller ambit, for example the lake trout lives in the lake and reproduces in the river. For other species, migrations may not necessarily be vital, but are desirable for their life cycle from juvenile to adult fish and for gene exchange or other reasons.

The migration of fish in river systems is hampered by building structures. Numerous transverse structures have been erected by humans to stop the depth erosion of rivers, weirs have been built to divert water or hydroelectric power plants block the path of migrating fish. These obstacles result in fish migration being completely prevented or at least severely slowed down, fish in turbines, sluices or spillways are hurt or die, fish fall victim to predatory fish or fish-eating birds in their search to overcome the obstacles, or die as a result of a change in water quality.

The European Water Framework Directive (WFD), demands to ensure the best approximation to the ecological continuum, including upstream and down-stream migration of all species, as one of the hydro-morphological elements which sustain the good ecological status of rivers. In addition, European Council regulation no. 1100/2007 established measures for the recovery of European eel stocks. It includes the requirement that all member states reduce anthropogenic mortality factors and notably the injuries inflicted on silver eels migrating downstream and passing through turbines.



For hydropower installations, new fish passage facilities and connections to adjoining waterbodies must be erected, and existing structures must be reviewed and may have to be adapted if they do not function properly according to WFD and regulation no. 1100/2007.

While upstream migration seems to be solved by nature-like or artificial fish-ways and fish passes, downstream migration still poses a major challenge. Fish can drift downstream with the main current and reach the trash rack systems at the turbine intakes. Following the main current they are unable to find a fishway or there is no alternative way to bypass the turbine, so that they often end up being carried into the downstream by the turbine and thus often suffer fatal injuries.

### 3.7.2 Solutions for upstream migration

Three kinds of solution can be set up in order to restore, at least partially, upstream migrations at obstacles:

- Removal or levelling of transverse structures i.e. obstacles. Removal of these structures such as sills, weirs, dams and hydropower plants is a definitive solution to restore a complete ecological continuity, but it is not compatible with hydropower production and other water uses.
- Construction of fishways. This is the classical solution, compatible with hydropower production, as a small part of the potential intake discharge is used to supply the fish passage device.
- Management operations. This kind of solutions includes the targeted opening of mobile units (rare in hydroelectric production contexts) or the use of navigation locks attached to power stations (to date in France one example on the Rhône River).

The “Trap and Truck” method can constitute a fourth solution but is rarely used, as it needs high reactivity from the staff and diverse fish manipulations which may cause fish injuries. It can nevertheless be justified for bypassing a significant number of successive arrangements and in the absence of interesting habitats between these arrangements for the target species.

#### 3.7.2.1 Removal or levelling of transverse structures i.e. obstacles

This option is not considered here because it is not in line with hydropower energy production. Information on the topic can be found in the EU-H2020 project AMBER (<https://amber.international/>).

#### 3.7.2.2 Fishways

A fishway can be either natural or completely artificial. There are several different types of fishways: Pool-type fishways, nature-like or rough bottom fishways and baffle fishways. The principle of these fishways is the same: The fish should be able to overcome the height difference in a short distance, but the energy in the fishway must be converted efficiently so that the speeds are not too high and the swimming power of the fish is sufficient to move through the fishway. To make this possible, the fishway should also have calm zones in which the fish can rest. This can be achieved with different fishway designs.

While in the past the main focus was on the ascent of fish from downstream to upstream, today's fish pass should also meet other requirements if possible. Therefore, the function of a fishway as a habitat is becoming more and more important. While both an artificial and a given fishway can be used purely for migration, the nature-like fishway has decisive advantages as a substitute habitat for fish and other aquatic species (Figure 76 to Figure 78).



Figure 76: Pool type (left) and steep baffle type (Denil) fish pass (right) (source: J. Geist, P. Rutschmann)



Figure 77: Combination of different types of ramps, with concrete elements in the foreground and steep, rough ramp in the background (source: P. Rutschmann)



Figure 78: Nature like fishway at Freudenu HPP, Austria (source: W. Reckendorfer)

### 3.7.2.3 Fishways for eels

Eels can also migrate in ordinary fishways. However, it is more efficient to use specially planned migration paths. Eels have characteristic features that a specific design can take better account of. They have a very long body and very individual swimming movements, which can be accommodated with the appropriate substrate (Figure 79).



Figure 79: Eel ramp covered by a brush type substrate (left) and (right) a concrete cones substrate (source: AFB)

### 3.7.2.4 Fish lifts

Fish lifts are used where the difference between upstream and downstream is too high to be overcome with conventional fishways (Figure 80). They work in such a way that fish swim into a tank which acts as trap, are then unable to leave and are lifted into the upstream by a mechanical system. In order to motivate the fish to swim into the trap, there must be a sufficient current. When the fish have reached the top, they are tipped out or the tank is opened and the fish can swim into the headwater. Fish lifts are used where conventional systems fail. The fish lift principle was first used in the USA on the Connecticut River.



Figure 80: Fish lift Runserau, Austria (source: M. Schletterer)

### 3.7.2.5 Fish locks

Fish locks work very similar to ship locks (Figure 81). Fish swim into a chamber which can be closed off against upstream and downstream by means of gates. When the downstream gate closes, water from upstream flows into the lock and the water level rises. When the water levels in the lock and the upstream reservoir have equalized, the upstream gate is opened again and the fish can swim out. Fish locks were first used on the Columbia River in the USA. However, their efficiency proved to be very modest and most locks have since been replaced by conventional fishways.



Figure 81: Fish lock at the Jeging 2 HPP, Austria. (source: M. Schletterer)

### 3.7.2.6 Specific solutions Management operations

Besides the classical solutions shown above, there are also very special approaches to support the upstream migration of fish. These include the adapted operation of ship locks, the partial permeability of hydropower plants at important migration times, the transport of fish by trucks or similar. Recently, interesting upstream migration facilities have also been presented, which need to be further developed and investigated. For example, the innovative screw elevator system by REHART/Strasser, in which fish are lifted to a higher level by a counter-rotating Archimedean screw (see [www.rehart-power.de](http://www.rehart-power.de)), or the Whooshh (“the salmon cannon”) which can transport fish in a hose over great lengths and heights (see [www.whoosh.com](http://www.whoosh.com)).

## 3.7.3 Solutions for downstream migration

### 3.7.3.1 Introduction

According to the EU-WFD fish and other aquatic species must be able to migrate in rivers in both directions. While there is a lot of knowledge about the migration of fish into the headwater, the possibilities of fish migration into the underwater are much less investigated and special solutions for fish descent exist only exceptionally at existing facilities. Multiple fish passage options exist for fish to pass downstream through the dams such as downstream migration bypasses, fishways, spillways and turbines. Usually fish follow the main flow when migrating downstream and therefore often are attracted by the turbine intakes and miss downstream migration options such as fishways. Nevertheless during floods many fishes use open spillways to migrate over barriers.

For downstream fish migration the FIThydro project has mainly investigated by-pass options to which fishes are guided by racks or louvers. Functioning bypass options for smaller sized or medium sized hydropower plants exist. Fish are guided with narrowly spaced trash racks, either horizontally or vertically inclined, to a bypass. However, for power plants at large rivers the respective solutions have clear disadvantages. The trash racks used for guidance are long and costly, trash rack cleaning is difficult and large hydraulic losses occur especially when

the racks are blocked by debris. Furthermore in the FIThydro project mortalities in turbines were investigated and from these investigations knowhow on how and where mortalities occur has been raised.

### 3.7.3.2 Solutions to avoid/limit mortality

Fish protection technologies at HPPs to avoid or at least limit the mortality of fish moving downstream are conceptually classified into two categories namely (I) Screening/Shielding and Guidance and (II) Conveyance. Selection of one or more of the measures depends on fish species as well as flow and site conditions at the HPP. The following measures are further explained:

- Fish-friendly turbine operation (targeted shutdowns of the turbine);
- Fish-friendly turbines;
- Sensory, behavioural barriers associated with bypass systems;
- Material barriers, generating behavioural and/or physical blockage including skimming walls, louvers, inclined racks, angled bar racks (with vertical bars) and horizontal bar racks associated with bypass systems.
- Horizontal racks and innovative HPP designs

### 3.7.3.3 Fish friendly turbine operation

Without modification of the water intake, the shutdown of conventional turbines is the only solution to avoid turbine passage and the corresponding fish mortality rates. This solution can in principle be effective but can become very costly for the hydroelectric operator if the shutdowns are not targeted. The challenge is not only to target, but also to anticipate the events of downstream migration. A targeted shutdown is frequently used during migration of eels in conjunction with a biomonitor, such as the Migromat, that indicate beginning and end of the eel migration period. The solution could also be used during smolt migration, however the migration period of young salmon is long and the production losses due to the shutdown high. An approach combining environmental parameters like discharge, temperature, turbidity etc. with fish motion data from radio telemetry studies can help to better predict migration periods of fish species (see Bruijs, et al., 2003). Fishfriendly turbine operation also includes avoiding part load operation. For Kaplan turbines, the mortality increases as the discharge is reduced, notably due to the reduced space between the blades (Berg, 1986 and Bruijs, et al., 2003). The effect of such "fish adjusted turbine operation" was simulated for eels on the Moselle River: in combination with a "catch and carry" measure, it produces only a gain of 2 % on survival rate (Kroll, 2015).

### 3.7.3.4 Fish friendly turbines

One solution to avoid or at least limit the mortality is to modify the turbine design to eliminate each source of damages on fish (strike, pinching-grinding in gaps, pressure change and cavitation, shear and turbulence). Several turbines were developed for low head HPPs like the Archimedes or hydrodynamic screws, the VLH (very low head) turbines, Pentair Fairbanks Nijhuis/FishFlow Innovations Turbine, the Alden turbine or the Minimum Gap Runner (MGR) as are shown in Figure 82. For further details on these developments, please refer to the corresponding literature.



**Figure 82: View of fish-friendly turbines: screw (up left), VLH (up right) (source: MJ2 technologies), Pentair fair-banks (down left) and Alden turbine (down right)**

As an alternative to a new fish-friendly turbine the IDA (induced drift application) fish protection system was investigated during the FIThydro project. The IDA device was invented and developed at Technical University of Munich (TUM) and TUM holds an EU patent (EP3029203) on the device. IDA intends to increase survival rates by targeted behaviour manipulation of fish during turbine passage. Passage location, fish orientation and swimming behaviour are influenced in a way to optimize survival of fishes during the risky turbine passage. IDA is a very simple device with which turbines can be retrofitted with little effort.

In principle, electric fields, light or ultrasound can be used to influence fish behavior. Electric fields are particularly effective and fish show a direct effect on them (Figure 83). At low field strengths fish are deterred, at higher field strengths fish are attracted by the anode. If the field strengths are high enough and the influence is long enough, fish can also be anaesthetised, so-called electro-narcosis. An appropriate field strength can therefore lead fish to a point of entry into the turbine with a high probability of survival and the narcotised fish cannot perform dangerous swimming movements during the turbine passage. First results have shown that mortality with IDA is reduced to about half and further improvements seem possible.

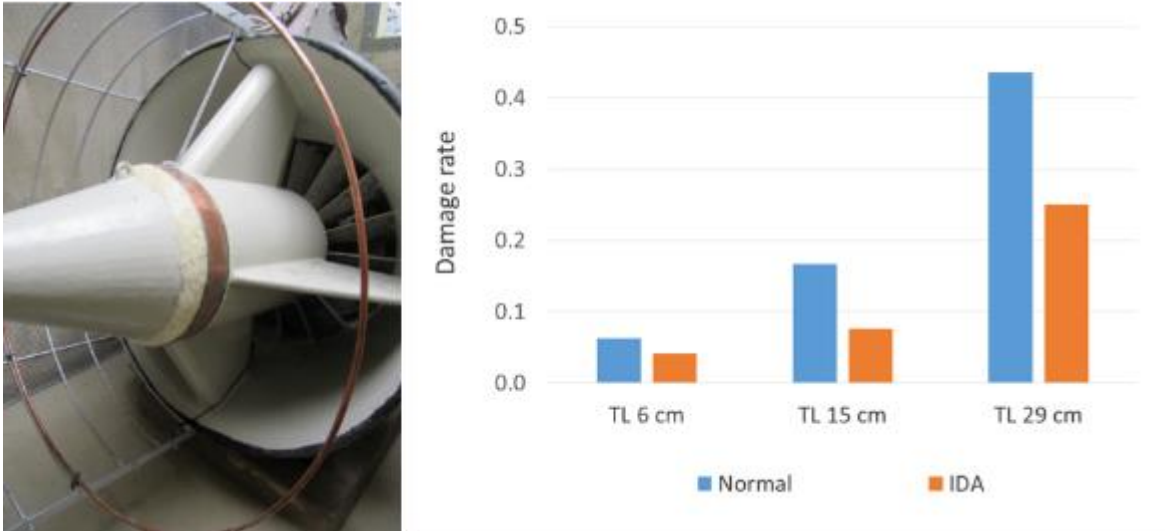

Figure 83: IDA pilot at the 35 kW test case Kaplan turbine intake with the two ring-shaped copper electrodes (left) and observed damage rates for fish passage without (blue) and with IDA pilot device (red) for varying fish lengths (total length TL)

### 3.7.3.5 Sensory or behavioural barriers

Sensory behavioural barriers modify the fish environment by taking advantage of their natural response to various stimuli (sound, light, electric screen, air bubble curtains, chain screens etc.) to guide the fish to a safe route (bypass entrance, spillway or other types of passages). Such barriers are convenient for designers and users alike because, unlike physical barriers, they require only minimum maintenance and cleaning efforts against blockage.

Promising results have been obtained with various experimental behavioural screens in laboratories or on test sites. However, not many prototype installations have been evaluated. Furthermore, the technology has not met the expectations and the results obtained in field applications have been much less reliable than those obtained under controlled conditions. Furthermore, their scope of application is limited to low flow velocities (<0.3 m/s). ( EPRI, 1986) (Kynard, et al., 1990), (EPRI, 1994), (Gosset, et al., 1999), (Therrien, et al., 1998) (Travade, et al., 1999), (Larinier, et al., 2002), (Bau, et al., 2008) ).



### 3.7.3.6 Material barriers

#### 3.7.3.6.1 Skimming walls

Skimming walls (or surface mask) can be used to deflect those species that migrate in the surface layers, such as salmonid smolts. This device is inefficient for bottom-oriented species, such as eels. A guide wall must cover a certain depth to generate a sufficient repelling effect and must be installed at an angle to the channel intake to guide fish to a bypass entrance located at its downstream end (Figure 84).

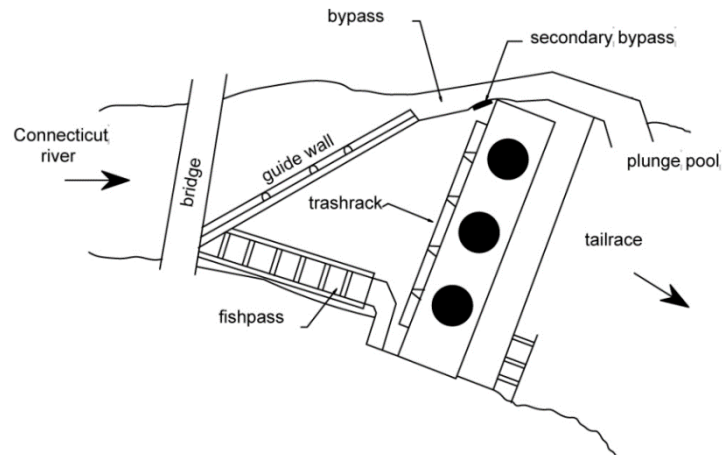

Figure 84: Skimming wall at Bellows falls power station (Odeh, et al., 1998)

#### 3.7.3.6.2 Bypasses combined to conventional existing racks

From the 1980s to the early 2000s, research was conducted, mainly in the USA, Canada and France, to assess the efficiency of surface bypasses combined with conventional bar racks existing at HPPs for turbine protection (not too expensive and cumbersome solution). Most studies focused on salmonids. The experiments have shown that the efficiency of these systems is heavily dependent on the repulsive effect of the bar racks on fish, the velocity pattern in the canal intake and the design of the bypass entrance (Larinier, et al., 2002).

In brief, for Atlantic salmon smolts, the guidance efficiency of surface bypasses combined with existing bar racks varies between 10-20 % to 80-90 %. For bar spacing larger than 50 mm the efficiency is low, for bar spacing of 30-50 mm the efficiency is medium and for bar spacing of 25 mm the efficiency is high (Larinier, et al., 2002).

Studies conducted on eels revealed that the efficiencies of surface or bottom bypasses combined with existing bar racks were much lower than for smolts, as eels do not show strong behavioural repulsion and are therefore likely to pass through the racks (Figure 85).

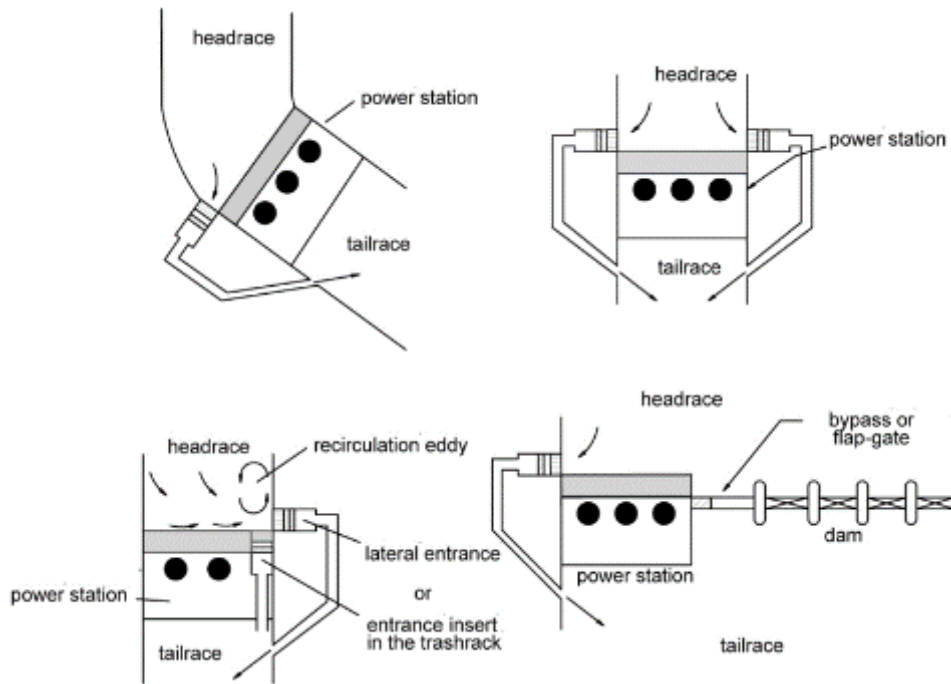

Figure 85: Conceptual plan of the location of downstream bypasses at hydroelectric plant intakes (from Larinier, et al., 2002)

### 3.7.3.7 Fish Guidance Structures

The design of racks or louvers as fish guidance structures should comply the following criteria: (I) efficient fish protection and guidance, (II) reduced head losses, (III) robustness against driftwood and sediment clogging and (IV) economy (Albayrak et al., 2017).

The challenge is to collect and guide a high number of downstream migrating fish with a low proportion of the discharge (few percent of the maximum turbine discharge). To achieve high efficiency, the fish guidance structures should protect the fish from entering the turbines; guide them towards bypasses without a significant time lag and transfer them downstream without any damages.

Fish guidance structures are classified into two main categories: (I) inclined bar racks and (II) angled bar racks and louvers.

#### Inclined bar racks

Inclined bar racks (Figure 86 and Figure 87) are installed perpendicularly to the flow direction and at an angle  $\beta$  to the invert in order to guide fish towards one or several surface bypasses located at the top of the rack.

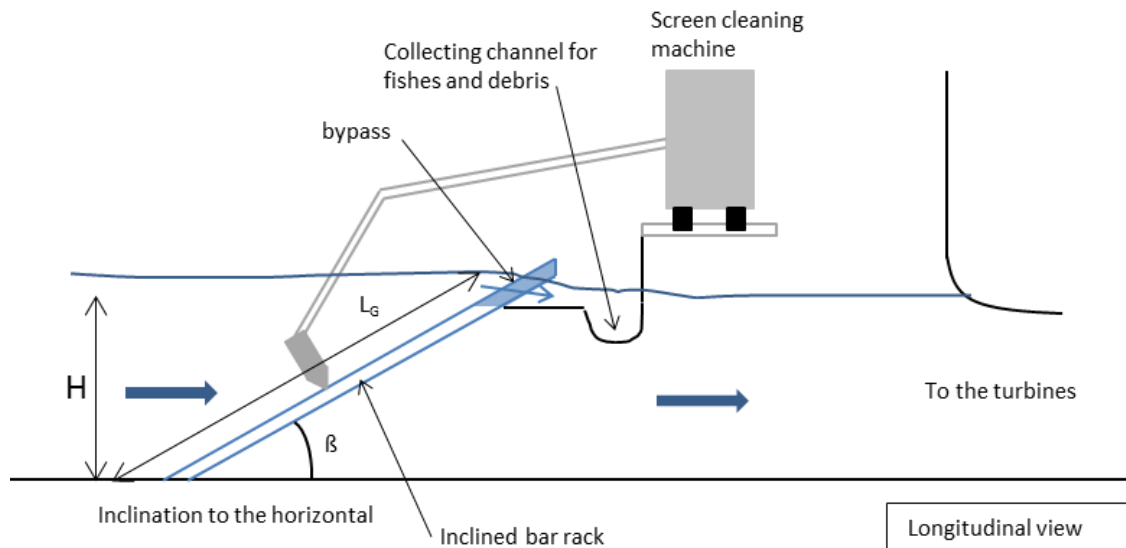

Figure 86: Longitudinal view of an inclined bar rack (source: Courret, et al., 2008)



Figure 87: Inclined bar rack with openings to the bypass channel system (source: P. Rutschmann)

#### Angled bar racks and louvers

Angled bar racks and louvers are installed at an angle  $\alpha$  to the flow direction in plan view to guide fish towards a bypass located at the downstream end of the rack. Four types of angled racks with vertical bars can be distinguished: “Classical” angled bar rack (Figure 88), modified angled bar rack (MBR) (Figure 89), angled bar rack with bars oriented in the streamwise direction and louver with bars perpendicularly to the approach flow (Figure 90).

These rack structures can act as a physical or behavioural barrier. It depends on the bar spacing and fish size. The rack constitutes a physical barrier when the bar spacing is lower than 1/10 of body length for most species including salmonids, and except for eels which require bar spacing lower than 3 % of their length (Ebel, 2013). Angled bar racks with horizontal bars constitute a fifth type (Figure 88). The typical bar spacing ranges from 10-30 mm. Thereby, horizontal bar racks act as physical barriers to the majority of fish. For louvers, fish perceive the highly turbulent zones around the bars, react with avoidance (behavioural barrier) and are guided to the bypass. Such “louver effect” also exists for the angled bar rack and modified angled bar rack.



Figure 88: The horizontal bar rack of residual flow HPP Schiffmühle, Switzerland, during reservoir drawdown in July 2018 (source: J. Meister, VAW)

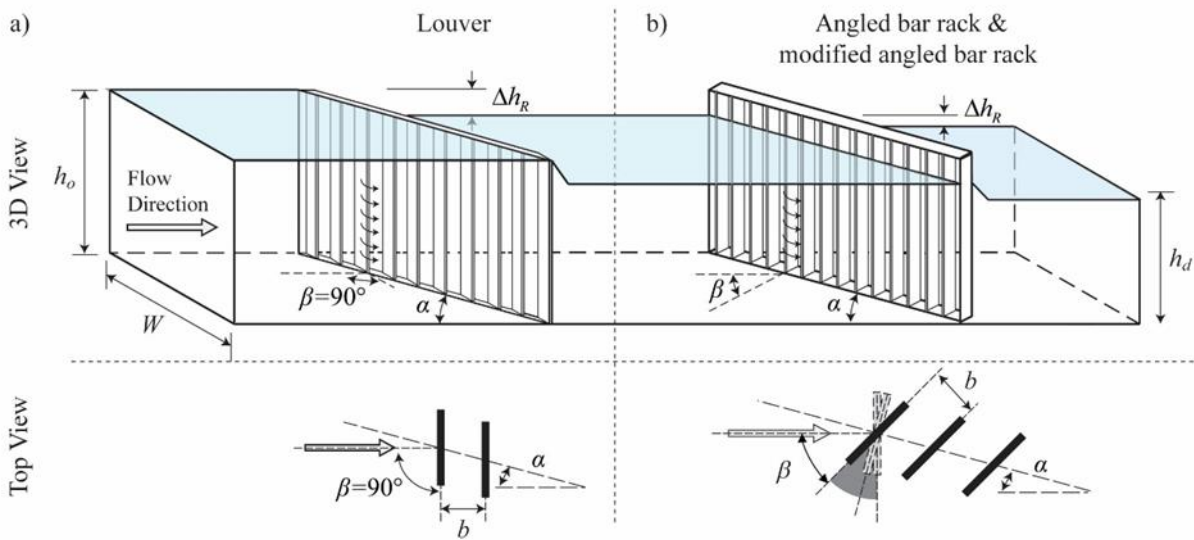

Figure 89: Detailed geometric view of louver, angled bar rack and modified angled bar rack (MBR) (from Boes, et al., 2017)

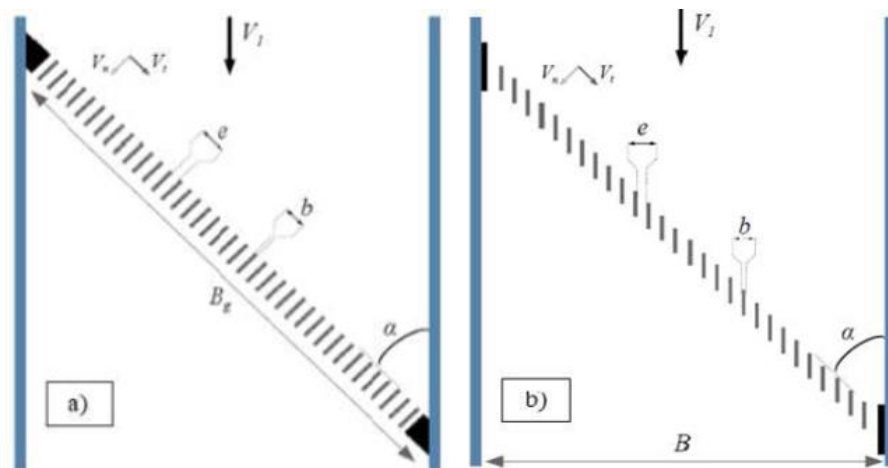

Figure 90: a) “classical” angled bar rack, and b) angled bar rack with bars in the streamwise direction (from Raynal, et al., 2014)

### 3.7.3.8 Horizontal racks and innovative HPP designs

#### 3.7.3.8.1 Horizontal racks

In mountainous regions, some of the water intakes are of bottom-type, also called Tyrolean intakes, particularly on streams with great sediment transport and sites with complex access. There are many examples of these water intakes, in mainly higher altitudes of 1,000-1,500 m altitude, with natural population of trout upstream. The rack or the perforated plate is included within the down-stream weir face, more or less inclined in the down-stream direction so that the trashes and sediments are pushed out by the flow (self-cleaning intake). Three types of such intakes exist: The classical bottom-type intake with longitudinal bars, the Lépine water-intake with a perforated plate and the Coanda water intake with transversal bars using the Coanda effect (Figure 91). At bottom-type intakes, downstream migration of fishes can be handled at the intake itself or downstream in desilting pools with “classical” fishfriendly bar racks combined with bypasses.



Figure 91: Coanda water intake illustration and example of Coanda water intake of Escouloubre (977 m altitude) on the Aude river, France (Source: AFB)

#### 3.7.3.8.2 Innovative HPP designs

A horizontal screen, a conventional but submerged Kaplan turbine with permanent magnetic generator, a downstream sluice gate which can be raised or lowered for trash rack cleaning or during floods and with surface-near and/or bottom-near openings in the gate for fish downstream migration are features of the TUM Hydroshaft Concept (Rutschmann, et al., 2011, Figure 92). The Small bar clearance ( $\leq 20$  mm), low normal velocities (0.3 to  $\leq 0.5$  m/s maximum value) and bottom-near and surface-near openings in the sluice gate immediately at the intake to the turbine and a natural behavioral barrier through the horizontal, bottom parallel rack are meant to provide favorable conditions for fish protection and downstream passage of fish. Experiments at a small scale prototype with trouts, graylings, barbels, bullheads and minnows showed high efficiency for potamodromous

species. The observed efficiency is 100 % for fishes more than ten times larger the bar clearance (except the eel) due to the physical barrier of the trash rack. For fishes smaller ten times the bar clearance, large partitions of downstream migrating fish passed through the bypass (e.g. 65 % of minnow (*Phoxinus phoxinus*) with 59 mm average body length and 60 – 80 % of bullhead (*Cottus gobio*) with 81 mm body length (Geiger, et al., 2016) depending on fish length, flow velocity and bar clearance. The found relations provide in principle further potential for ecological improvements. A first commercial facility of 450 kW is operational since beginning of 2020 and fish downstream passage investigations are currently conducted.



Figure 92: Visualization of the Hydro Shaft Concept (top line) and 450 kW at Grossweil, Germany (bottom line)  
(Source: top line: TUM and bottom line: A. Sepp)

#### Acknowledgement

The work and the ideas described here are the product of contributions of many people from the 26 partners in FIThydro. This project received funding from the European Union's Horizon 2020 research and innovation programme under grant agreement no. 727830.

## 4 SHP Development Process

The development of a SHP is a very complex process, which involves many specialist skills, needed to deal with the variety of problems that usually characterize the design of a hydro scheme.

In detail, the technical items include the following expert area:

- hydrology;
- geology and geotechnics;
- hydraulics;
- ecology;
- civil engineering;
- mechanical engineering;
- electrical engineering;
- electronic engineering.

Moreover, a specific expertise is requested for tenders management, authorization procedures and financial closure of the investment.

Therefore it is very important that the project of a hydroelectric plant is addressed by a team capable of working in close collaboration.

For SHP, this approach can be too expensive and therefore many of the skills are entrusted to a small team or even to a single designer, who must integrate the low level of specialization in certain areas with a long, specific experience in the hydroelectric field.

### 4.1 Planning and Design Process

A typical problem of the design process is not only technical, but also concerning how to finance it.

This is because developing a detailed plan runs the risk of spending money without being sure that then the plant will be built or, in any case, without knowing first what its possible profitability will be.

For this reason, it is appropriate to proceed with the intermediate, lower cost steps, before incurring the significant costs of a real feasibility study.

The steps of the design process can be the following.

1. Site selection
2. Prefeasibility study
3. Feasibility study
4. Construction design

Each step corresponds to a share of the final cost of the design and this allows to avoid high costs at the beginning and also to calibrate them according to the available funds: for example, the feasibility study can be developed only after having verified, through a pre-feasibility study, that the plant has a good chance of being feasible from a technical, environmental, legal and, finally, financial point of view.

#### 4.1.1 Site Selection

The site selection process usually starts from a theoretical analysis carried out in the office and it is accomplished by on-site visits.

The first selection, made on a cartographic basis (paper or digital terrain maps), aims to identify the sections of the watercourse where the energy gradient, i.e. the gravitational potential per unit length (kW/km), has the greatest values. This normally occurs in the sections between a river confluence (maximization of the available flow rates) and waterfalls (maximization of the head). For some countries, general studies are available on suitable sites for the hydropower exploitation and they are a good starting point for a preliminary site selection.

Once an interesting stretch of a river has been identified, it is mandatory to carry out one or more site visits, which basically constitute the first feasibility assessment.

In fact, these visits on site are a way to check if there are any site killing constraints, i.e. situations that undoubtedly advise against the construction of the plant, thus avoiding the costs of the subsequent study phases. The issue of this visit will not be numerical, but only YES, it is worth proceeding with further study, or NO, better to stop immediately to avoid throwing money away.

The killing constraints can be of different kinds; the most usual are:

- instability of the slopes, due to their geological nature, of the area where the main plant structures are planned to be installed: we underline that, from common experience, geological unexpected events are the main cause of the increase in the construction costs of hydroelectric plants, sometimes even going so far as to cause them to be abandoned in the executive phase;
- poor geotechnical quality of the ground on which the foundation of the main works (such as intake, pond, penstock anchoring blocks and powerhouse) are to be built, or the presence of groundwater very close to the surface of the ground; temporary geotechnical works often are a very significant part of the civil costs, especially for low head plants, moreover they are a time consuming activity;
- flood levels of the river that require large and expensive protection works;
- identification of existing or planned uses of available water for drinking, agricultural or industrial aims, which may be prioritized by law or by already stated rights over the envisaged hydroelectric one;
- problematical access facilities to the key parts of the plant and in particular to the intake works: technically, any difficulty can be overcome, but the costs can become unsustainable, with reference to the profitability of the plant, especially in the case of small plants;
- high environmental sensitivity of the areas involved in the scheme: also in this case suitable technical solutions can be found, which can however cause significant impacts on the profitability of the investment;
- existence of critical problems for the acquisition of the areas necessary to house the plant structures, for example for high economic value of the land; high splitting of properties; expected opposition of the owners to sell the areas; presence of taboo areas for religious reasons or related to specific traditions.

A very important remark: this first phase, and in particular the on-site survey, must be carried out by a very experienced engineer in hydroelectric plants, because a great ability is required to identify the most significant constraints, to be further investigated, based only on what he sees or with the help of very simple measurements.

We are used to compare this phase to the first examination at the first aid, where the experience of the doctor who performs it is essential to quickly assess the severity of the symptoms and decide which instrumental insights must be performed.

#### 4.1.2 Pre-Feasibility Study

The pre-feasibility study has the aim to decide whether to go on with the project and, if so, to settle the team which will follow it and look for the economic resources to finance it.

In this phase of the design process, the plant scheme is chosen among all possible ones and this allows to verify with good approximation the feasibility of the project from the technical, environmental, legal and financial point of views.



Ultimately, the main issues of a pre-feasibility study is an economic assessment of the investment, integrated with a technical description of the plant layout with a level of detail suitable for identifying, with sufficient reliability, the costs (construction and operating ones), the expected production, the destination of the energy produced and its value, the environmental impacts and their mitigation, the authorization process and the construction timing. Another important issue is the chapter Recommendations, where critical issues are quoted in order to be faced and removed in the following design phases. For example, these critical issues can be related to geology, sale contracts with private individuals or utilities, permits of various kinds or particular technical aspects of the scheme.

The drawings accompanying the pre-feasibility study have the minimum level necessary to fully illustrate the plant choices and to calculate the costs parametrically, i.e. starting from a database of similar schemes.

From a technical point of view, the four pillars on which the pre-feasibility study is based are the following.

- Topography. It allows to define the main issues that affect the plant costs and its performances, such as the gross head and the length of the waterways. The best option for low head schemes is the on-site survey by means of a total station. Otherwise, a suitable evaluation, at the pre-feasibility level, can be acquired on paper maps or digital ones, if available. The values from simple GPS devices must be carefully checked before using them in the computations.
- Hydrology. It allows to define the significant river and plant flow rates, that are: minimum flow rate during the dry season, maximum flood with different return periods (10; 50; 100 years); reserved flow for ecological purposes, maximum flow diverted by the plant; plant mean flow on multiannual basis (5 years minimum; 15 better; 30 best). If direct measures aren't available, at the pre-feasibility level the inputs for the hydrological analysis can be derived from similar drainage areas or from literature data regarding flow rates and rainfall distribution.
- Environmental analysis. A preliminary analysis of the environmental constraints is strongly needed to evaluate their outcomes, affecting the real exploitable flow rate and the costs of the scheme, due to the mitigation measures during both the construction and operating phases.
- Authorization procedures. Permits/licenses procedures can have dramatic outcomes on the design and construction costs, and on the project implementation time as well.

In addition to the above-mentioned topics, the pre-feasibility study must be supported by a market analysis to identify the buyers of the generated electricity, preliminary prices and duration of the power purchase agreement.

### 4.1.3 Feasibility Study

The feasibility study allows to define the plant project in all details, removing any critical issues reported in the pre-feasibility study. The drawings of the feasibility study are based on detailed topographic surveys, the costs of the civil works are calculated analytically, and those of the electromechanical works are based on offers from potential suppliers.

Basically, the feasibility study has the same structure as the pre-feasibility study, but it is based on more site-specific inputs and more detailed analyses. In particular:

- Topography: however it is performed, it must have a level of detail at least equivalent to a survey carried out by a total station
- Hydrology: possibly based on datasets from measures taken directly at the intake section. A good approach is to install a gauge station at the intake section immediately after the first positive evaluation of the site, in order to have some direct measurement at least during the time between the site selection and the feasibility study.

- Environmental assessment: if particularly sensitive sites are involved, it must be deepened with direct on-site measurements of the most critical parameters for the river biology.
- Geology and geotechnics: if critical situations are supposed to be there, sounding or drilling samples of the subsoil is recommended to be taken and analyzed in a laboratory; this is usually mandatory for low head schemes.

The market analysis must also be deepened in more realistic terms than the one reported in the pre-feasibility study.

## 4.2 Permits and Licencing Process

The implementation of a SHP involves many and quite different rules, some at National level, others at Regional, Province or even municipality level, and this means significant times and costs required to get everything needed to start the plant construction and the energy production.

At least the following licenses/permits are usually needed.

- Water right
- Energy generation
- Impact on water quality, flora and fauna of the river, and all environmental aspects
- Building law and construction requirements
- Connection to the grid
- Land properties

Usually the most critical procedures are related to the water use license, because they involve technical and environmental aspects of the project and, moreover, can be under the competition of other proposers interested to the same water exploitation.

Generally speaking, a quite effective approach is to share the project with the local communities, after the water right has been acquired, in order to remove, or mitigate at least, the main opposition causes.

This approach facilitates also the authorization procedures at National or Regional level, and it can avoid problems during the construction phase, always critical.

## 4.3 Financial closure

In the prefeasibility study a financial survey can be quoted, based on usual financial inputs, but at feasibility level the financial analysis and the final financing scheme design should better be carried out by the financial manager of the proposer or by an external consultant.

This is because the final financial assessment is very sophisticated and requires some inputs that strictly depend on the specific situation of the proposer, such as, for example: possible savings on the taxation of proposer profits following the investment; specific depreciation facilities by law; equity share of the investment; already existing access facilities to bank loans for the proposer; National or International incentives for the RES production or, in general, on new investments, and so on.

Also the managing costs of the plant can be affected by peculiar situations of the proposer, such as, for example, already existing teams managing other hydropower plants or the equipment installed in the firms owned by the proposer; external firms specialized in the plant management available not too far from the plant site, specific insurance facilities for the proposer, and so on.

Consequently, the technical designer must provide the following issues with great accuracy to the proposer:

- construction costs;

- construction schedule, including the related cashflow;
- annual energy production (the net amount that can be sold!) and expected starting date of production (incomes start);
- costs for O&M (manpower, spare parts and technical depreciation);
- technical life of the main components of the plant: civil works (different values can be set for intake, dams, waterways, powerhouse and ancillary facilities); electromechanical equipment (different values for rotating machines; electrical components; electronic devices, power lines and so on)
- a risk analysis, to be taken as a basis for the insurance contracts.

#### 4.4 Construction and commissioning

Before starting with the building activities, a construction design – also called detailed design – must be implemented.

Basically, it contains all the construction details, such as the steel bars for the reinforced concrete; detailed schemes for the plant structures tracing on the site; technical specifications for the construction materials, contract documentation for the suppliers and so on. Moreover, it includes the technical specifications for the electromechanical supplies, that are mainly generating units, units and plant control panels, electric cubicles, transformers, remote control facilities, cranes, electric lines.

Since the authorization procedures often cause changes to the initial project, construction design should only be implemented after all permits and licenses have been obtained.

The design must comply with the national standards, but, if the national standards do not cover all aspects of hydropower, it can conform the international ones, such as the EN-ISO regulations or USACE guidelines.

The construction design is also a good documentation to manage the main procurements, because it describes in detail works, supplies, and the site-specific constraints that could affect the contractual obligation and prices.

With respect to the construction activities, it's a common experience that the hydropower plant construction is a long process, because it's very often located in remote areas characterized by quite difficult access facilities. Moreover, the weather conditions can interfere with on-site activities, even stopping them during the rainy or cold seasons. Other time constraints come from the equipment supply, which needs significant amount of months to be delivered and commissioned; the overseas transports and the related customs procedures, sometime complex and time consuming; the access road and other infrastructures to be previously built, than rehabilitated after every rainy season. Considering all these items, the construction of a SHP typically takes 12-24 months.

When the plant has finally been completed, the design enters another challenging phase, the plant commissioning.

A typical commissioning procedure follows the following steps.

- An overall inspection of the works and equipment, to verify that they comply with the contractual specifications
- Checking that the relevant documentation concerning the quality certifications and tests in the factory or on site is available and consistent
- Dry test, to verify the basic operation, mainly the ones connected with the emergency situation (safety valves and gates, for examples)
- Plant start-up chain activation and functioning test up to the maximum capacity, including the automatic parallel with the national grid if requested
- Performance tests to assess the unit efficiency (overall or separately for turbine and generator, depending on the contractual statements)

- Trial operating test, that means monitoring the unit in operation without any failures for a stated time (usually 10-15 day for the SHP)
- Specific and thorough training of the plant operators

Only after the plant passes all the above-mentioned tests, the warranty period of the equipment can start.

To finalize the commissioning, it is strongly recommended to deliver the “as built” version of the drawing, that are key elements for carrying out the plant O&M activities in a safe and efficient way.

## 4.5 Operation & Maintenance (O&M)

The plant performance, and its lifetime as well, dramatically depend on the operation and maintenance quality.

In order to achieve it, the best way is to introduce in the contracts with the main suppliers a clear obligation to carry out a thorough training of the operators, based on clear and complete manuals and practical exercises.

At the end of the training activities, operators are requested to assess them, by declaring that they have received a satisfactory training to safely operate the plant in every working situation.

A very significant improvement should be to involve the future plant managers in the erection activities, so they achieve a deep knowledge directly working on the equipment that they have to maintain afterwards.

It is important to underline that the suppliers manuals are only a part of the plant O&M manual, which must include the instructions to operate and maintain the civil and hydraulic works, that typically can cause the most dramatic and dangerous outages of the hydroelectric plant.

A typical index of the O&M consists in the following chapters, at least.

- Plant description and operating limits
- Administrative documentation (permits, licenses, contracts, monitoring and commissioning reports, ...)
- Technical documentation (as built drawings, technical specifications, equipment manuals, ...)
- Instructions to activate the water derivation (detailed description of the operations on gates and valves; parameters to be monitored during the operation, ...)
- Instructions to start and to stop the generating units and manage them in every operating condition
- O&M: daily, weekly, monthly, and annual activities, listed also in suitable checklists
- Template of the register where every O&M activity is recorded

## 5 Project Finance for international Small Hydropower Projects

The main concepts underlying terms and conditions of finance are 1) the theoretical risk-determinants from the Capital Asset Pricing Model and 2) the method of financing i.e. corporate and/or project finance. For ease of understanding the financial landscape for energy access finance in emerging markets some finance concepts are explained first. These are: 1) The Capital Asset Pricing Model (CAPM), and 2) Project Finance versus Corporate Finance.

### 5.1 The Capital Asset Pricing Model

In finance, the CAPM is a model used to determine a theoretically appropriate 'required rate of return' of an asset which allows to make decisions about adding assets to a diversified portfolio (Chong, Jin, and Philips, 2013 and Chen, 2019). The CAPM is a model for pricing of an individual security or portfolio, derived from the academic world in the 70's of last century. The details of the CAPM can be found in any finance textbook. The underlying relationship between perceived risk in combination with the time-value of money and the required reward is central in the model (the higher the perceived risk the higher the required return).

The **(international) CAPM** is accompanied by a formula (Kenton, 2020) which is shown here since reference will be made to some components furtheron in this chapter.

The **risk-free rate of return** accounts for the time-value of money and is typically an investment in government bonds of high credit rating (AAA for example), an investment of 'zero risk'.

The **beta of an investment** is "a measure of how much risk the investment will add to a portfolio that looks like the market (beta larger than one increases the risk of a portfolio, lower than one reduces such risk)". The **market risk premium** is the return expected by investors or lenders on top of the risk free rate of return.

The perceived risk and the translation into the required reward at the individual proposition's level is referred to as the '**cost of capital**'. As a tool for investment it dictates to invest in initiatives and projects that will provide returns that exceed the cost of their capital. The cost of capital includes both the cost of equity and debt in a weighted manner in accordance with a preferred or the existing capital structure of a project or company. Calculated this way it is referred to as the 'Weighted-average Cost of Capital' (WACC).

The cost of debt is the interest rate a company or the project is charged, but net from corporate taxes since interest in most cases is tax-deductible. This can also be captured in a formula as per the box to the right (see source CAPM).

$$\text{Cost of debt} = \frac{\text{Interest expense}}{\text{Total debt}} \times (1 - T)$$

**where:**  
 Interest expense = Int. paid on the firm's current debt  
 T = The company's marginal tax rate

The cost of equity generally speaking is more complicated to calculate since the rate of return required by investors is not as clearly defined compared to the cost of debt, in specific the 'beta' component which is often approached as an average beta of a group of similar (publicly-listed) companies. For the cost of equity the same calculation is performed as in the CAPM and depicted to the right.

$$\text{CAPM(Cost of equity)} = R_f + \beta(R_m - R_f)$$

**where:**  
 R<sub>f</sub> = risk-free rate of return  
 R<sub>m</sub> = market rate of return

The working of the WACC in renewable energy propositions has been investigated in a H2020 project called Aures II (2020). It is interesting to learn about the differences Aures found in cost of equity (range 6.0-20.0 %), cost of debt (range 1.7-11.0 %) and the overall cost of capital (range 3.0-13.7 %) for the 28 European countries at the time (2014-2016). The differences were attributed to

1. country specific risks (independently from renewable energy risks),
2. specific renewable energy risk premium for respective country, and
3. competition between investors and banks. Also, the effects of cost of capital on levelized cost of electricity (LCOE) have been found to be very significant.

'Risk' is a relative concept and in finance it is often broken down in components. A good example is 'country risk' which is in the above study by Aures one of the main causes for differences in WACC, leave alone for emerging markets. This risk category is widely covered by among others 'credit agencies'. A rating below BBB is non-investment grade or 'speculative'. Projects or companies generally speaking cannot be rated higher than the country in which they are established / operate from. International (commercial) banks need to meet Basel-solvency requirements (the international regulatory requirements for financial institutions) which are too high for activities in countries with speculative ratings – pricing of a loan to compensate for this would simply lead to uneconomic investments vis-à-vis what for example financial development institutions ('DFIs') can offer.

The 'country risk' is one of several risk categories that are at play in the risk assessment of a renewable energy asset risk class. It is probably the most important one since it determines to a very large extent the possibilities in finance. Mind, credit agencies perform rating tasks by rigorous analysis where all risks assessed are weighted relatively against each other. Renewable energy propositions in emerging markets often have no associated credit rating.

## 5.2 Project versus Corporate Finance

Another important concept in understanding finance of energy access in emerging markets is the understanding of two distinct ways of financing an asset. An 'asset' in this chapter is used as reference to a renewable energy proposition in the form of an income earning project or corporate. An investment in the shares of the project or into a company is referred to as an asset for the equity provider and a loan to the project or company is an asset-position for a loan provider.

Finance is about **risk analysis, risk mitigation and risk allocation**. Very high-level it comes in two flavours: 1) corporate (or company) finance, and 2) project finance.

**Project finance** originated from the allocation of finance to an externalised (new) company because corporate finance would create too much single-asset risk on the balance-sheet of the corporation i.e. the oil industry used this structure because one exploration-venture could have a tremendous impact on the balance sheet.

Because of the energy crises in 1973 and 1979 the United States adopted legislation by the Public Utility Legislation Policies Act ('PURPA') in 1978 aimed in first instance at energy efficiency but used in the 1980's to introduce private sector generation of electricity under the **independent power producer scheme** ('IPP') with pre-set parameters like 40 % equity and a certain minimum equity return threshold (American History, 2020). PURPA allowed for a large portion of 'guaranteed' payments for the capacity added to the grid ('Capacity Fees') and some fees for compensating fully running cost ('Energy Fees'). This 'IPP'-scheme was exported to emerging markets through companies like Enron, AES, but also in other infrastructure sectors like water. The underlying principle is the CAPM which stipulates a.o. that more (perceived) risk requires more expected equity returns as indicated earlier. Hence, on a 40 % equity in a project the return requirements in Africa often have > 20 % (Harper, 2015) per annum (in hard currency) in addition to stringent risk mitigation measures such as full termination compensation clauses, etc. and all guaranteed by respective government or even reserved already.

Project finance is lending to a special purpose vehicle/company ('SPC'). Project finance is based on analysis of future cash flow as presented in a business plan and reflected in a financial model. Key 'monitoring' covenant is the minimum debt service coverage ratio ('DSCR') which reflects how much net cash is required in future in relation to debt service obligation i.e. if 100 is the debt service (interest + principal repayment) in a given year than the DSCR needs to calculate how net cash relates to this (if net cash is 150 in that year the DSCR is  $150:100 = 1.50 \times$ ).

**Corporate finance** is lending to a corporate entity, being a start-up or an established company. In corporate finance the debt capacity is determined by track record of the company and the strength of the balance-sheet among others the equity available or the possibility to call in equity if and when deemed required (for cost overruns for example).

The **debt servicing capacity** is often considered maximized against an equity (including subordinated debt) position of some 40 % of the balance-sheet, i.e. 60 % borrowing but obviously to be justified by the underlying business plan on future debt service possibilities. Key 'monitoring' covenants are the Debt:Equity Ratio (D:E ratio) and liquidity ratio's. Liquidity ratio's express the firm's capacity to meet short term obligations such as the current ratio which determines short term liquid assets divided by short term (debt) obligations and which indicates a healthy situation if this ratio is 1.5 x or higher.

Corporate finance can be considered by a lender or investor at any moment, project finance generally works towards one moment ('financial close'). Portfolios of smaller 'projects' (like rooftop solar) can have both timing elements simultaneously (a loan to the company but allowed for disbursement at reaching milestones at each rooftop-project level) but most often sequential finance is the case. It is also good to mention that corporate finance much more has to consider vested interests from for example existing lenders (new borrowing subject to approval from existing lenders) compared to project finance.

The CAPM and the IPP-schemes were both developed in the last century and had a strong influence on each other. The legislation accompanying the IPP-schemes to allow for an enabling environment for the mobilisation of the private sector funders served as a standard for many other countries. At banks the risk allocation process in IPPs and the governmental support became the parameters for the funding of IPPs detailed in 'internal policy papers'. These policies allow the 'front-office' to structure transactions in a way credit analysts are able to evaluate against the internal investment or lending policies. Also, for selling down loans to other funders the policies are to some extent accepted amongst most financial institutions that have a focus on the energy sector.

Renewable energy' as a financial '**asset class**' can be financed by the private sector very well and lends itself for far-stretched standardisation and therewith securitization. Understanding finance of renewable energy by the private sector in 'perfect' financial markets makes clear where finance is different in 'imperfect' financial markets which includes the markets where HYPOSO has its focus. This understanding allows for determination of the best interventions, if any, but it allows as well to realistically map sources of funding since they are not as widespread in imperfect markets.

Full market-based solutions are less bankable in emerging markets and negotiated or 'unsolicited' transactions are difficult to embrace by governments ('tomorrow a better deal can be offered'), so in practice the feed-in regime proved some value for many years in many countries. Nowadays, more and more countries adopt an 'auction-system' either within a feed-in regime (provides for upper maximum bidding price) or not.

The European Union realised the importance of auctions many years ago and supported a large consortium under the H2020 program to define the enabling environment for auctions. The H2020 project is named Aures – promoting effective renewable energy auctions (AURES project, 2017). The delivery models are also applicable to hydropower projects although the characteristics of hydropower projects do not allow easily for tendering / auctions since most projects are very site-specific. The expenses incurred for development of such sites is often a barrier in case in the end tendering is requested (AURES II project, 2020).

### 5.3 Funding sources

Due to Basel-regulations international commercial banks are not very active, if at all, in funding directly renewable energy in emerging markets, leave alone to small-scale hydropower assets. If they are active in emerging markets they are so in financing assets for example that require much shorter tenors compared to renewable energy, 3 to 5 years (in telecom transactions for example) versus 10 to 18 years.

Without the international banks the private sector from a funding perspective is largely absent and therewith also the ‘bridging vehicles’ to institutional investors, pension funds, insurance companies, retail lender, etc. The following graphs show high-level the ‘gap’ in availability of financial sources for renewable energy in emerging countries with non-investment grade ratings:

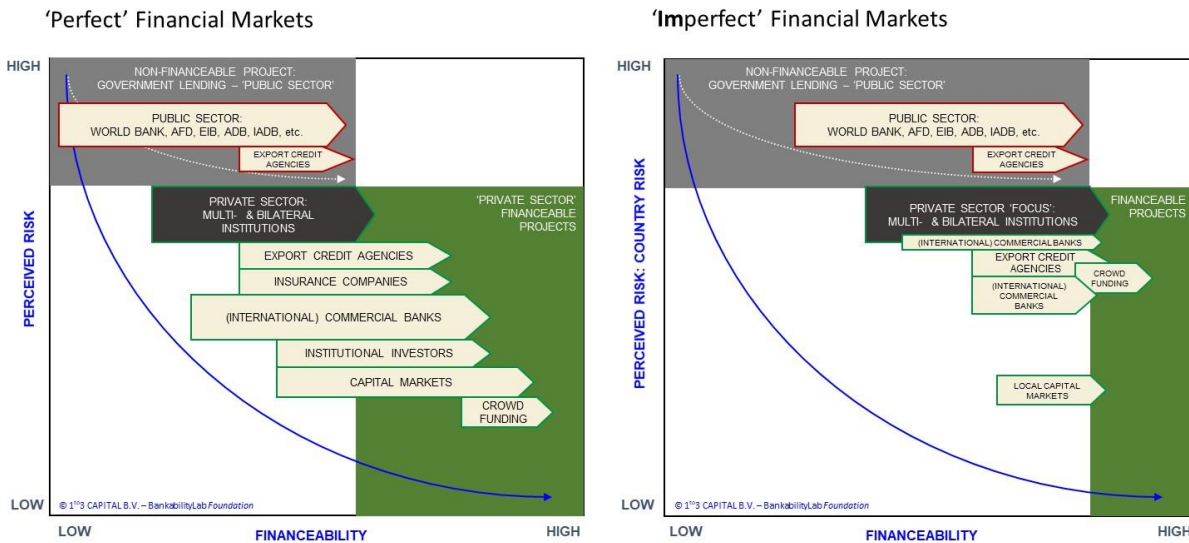

Figure 93: Perfect and Imperfect Markets (1to3 Capital)

These (overly-simplified) graphs aim at showing the lack of some funding sources for renewable energy, like institutional investors, commercial banks, etc. in emerging markets, at least absent at some desired scale. Because of the lack of some major blocks of funding also the number of financeable projects falls short with expectations and international 2030-goals regarding climate change targets. The projects that are developed will need to be adopted by lesser institutions and relatively more of these institutions are development agents that in principal ‘cannot’ advise since then they also need to provide the money (they are the so-called ‘lenders of last resort’) and they are ‘equals’, hence, apart from IFC not one of them stands out as lead arranging with ‘underwriting’ on behalf of others which is a common approach among commercial banks. ‘There are no bankable projects’ is often mentioned for Africa and South-East Asian countries. Other regions like Latin America face a lack of funding for certain type of projects like small scale hydropower, e-mobility, etc. Further, because development institutions cannot distort the market the CAPM is very well-alive in funding decisions in emerging markets, no matter if one is supportive at all to the theoretical CAPM-scheme. Mind, ‘lender of last resort’ also often indicates that there is a lack of equity in the market which is a bracket also offered by development institutions, hence, often in the same transaction equity and debt is provided which needs to be the more so to be market-conform i.e. CAPM-proof. Nevertheless, funding is available to and in emerging markets through schemes that intelligently work with or around these market-conformity rules. These are detailed in the next paragraphs more or less in the order of descending from the financial parties that can assume the most political risks to parties that assume these risks at a later stage either in the financing process or at lower risk levels.



## 5.4 Public Sector Funding and EXIM Banks

Finance parties that take account of large sums of finance to hydropower in emerging markets are the World Bank and EXIM Banks and Export Credit Agencies (ECA) which concerns public funding to the public sector (entities) in the emerging markets as depicted in the diagram to the right, but with some 'private sector characteristics'. The funding interest for the World Bank is based on its mandate to support in specific the International Development Association (IDA) - countries. For Exim Banks the support of its own industry that exports and/or realises works in emerging markets is the key driver for support.

### World Bank

The World Bank Group (WBG) takes a very prominent role in the segment of finance. The World Bank can be active in the public sector only and / or the private sector as well (IDA, 2020).

#### World Bank and Public Sector

A public sector intervention is for example a grant made available for a hydropower project. In 2014 for example the World Bank made USD 100 million available as a grant out of a USD 270 million project cost for the 'Jiji and Mulembwe' hydropower projects in the Republic of Burundi (The World Bank, 2014). Through its position the World Bank mobilised a 'coalition of donors that includes the African Development Bank (AFDB), European Investment Bank (EIB), European Union (EU), the Government of Burundi and the utility company Regideso.

The World Bank offers also 'concessional funding' i.e. funding at favorable terms and conditions which deviates from market prices that would be derived under 'CAPM' but are justified from international agreements to support the IDA-countries, a group of 74 countries at the moment: "IDA offers a range of financing products - from grants to loans on terms of the International Bank for Reconstruction and Development (IBRD) - that take into account the variations in economic and social development of IDA countries."

#### World Bank and Private Sector IDA-Countries

When the IDA facilities got replenished for the 18th time (IDA-18) the World Bank created a USD 2.5 billion private sector window (PSW) together with its subsidiaries International Finance Corporation (IFC) and the multilateral investment guarantee agency (MIGA) with the aim to catalyze private sector investment in IDA-only countries. IDA-19 is being proposed now at the same funding level of USD 2.5 billion. The IDA PSW is seen as an option when there is no commercial solution and the World Bank's other tools and approaches are insufficient. The IDA PSW builds on the World Bank's support for private sector investment in IDA countries in excess of USD 100 billion in the last decade: "The IDA PSW is deployed through four facilities:

1. **Local Currency Facility** to provide long-term local currency IFC investments in IDA countries where capital markets are not developed, and market solutions are not sufficiently available.
2. **Blended Finance Facility** to blend PSW support with pioneering IFC investments across sectors with high development impact, including small and medium enterprises

An example of the working of the IDA-PSW scheme is described below.

In the Solomon Islands, a 15 MW hydropower plant of USD 240.8 million is getting financed primarily through concessional loans and grants from DFIs. The plant and associated 72-meter-high roller-compacted-concrete dam are located on the Tina River, about 30 kilometers south-east of Honiara, the capital of the Solomon Islands. It is the first utility-scale hydro-power project to be developed in the Solomon Islands.

In this project MIGA issued guarantees for 90 % of equity investments (USD 14.1 million) to cover the investments and future earnings in the project for 20 years. The guarantees provide protection against expropriation, breach of contract and war & civil disturbance. The project sells electricity

(SMEs), agribusiness, health, education, affordable housing, infrastructure, climate change mitigation and adaptation, among others.

3. **Risk Mitigation Facility** to provide project-based guarantees without sovereign indemnity to crowd-in private investment in large infrastructure projects
4. **MIGA Guarantee Facility** to expand coverage through shared first-loss and risk participation via MIGA reinsurance.

The IDA PSW facilitates investments but does not fund private investment on its own. Through different facilities, it backstops or blends with IFC investments or MIGA guarantees to support private-sector investments.”

once operational under a 30 year power purchase agreement (MIGA, 2020).

Overall, the WBG seems to offer finance solutions from many angles at very substantial positions. The funding made available and mobilized from others appears truly unrivalled. Country to country support in one sector and specific one type of electricity generation often has many spin-offs which also benefit SHPs. For many countries it is already quite a quest to obtain funding for infrastructural works for the longer term, hence, if it is available at concessional terms at public sector level this route is preferred by many.

## 5.5 Development Finance Institutes and Development Funds

Parties that can be classified as development finance institutes are available at many levels throughout economies worldwide ranging from municipal development agents, provincial and industry development agents, regional and national development institutions as well as supranational entities, the multilateral finance institutions. A large group of these institutions is focussing on emerging markets or were established with the purpose to be active in emerging markets only.

Broadly speaking ‘two’ groups of development banks can be identified: 1) multilaterals where more than one government is shareholder / participant in the institutions (MFI), and 2) bilateral institutions with one government being (majority) shareholder and where the institute functions as an instrument for the country’s development agenda (DFI). Both type of institutions have an obligation to catalyse other funding (international commercial banks for example) and to be additional to market-participants.

### Multilateral Finance Institutions

MFI’s have the mandate to act both in the public sector as well as in the private sector. Most MFI’s make the focus between the two approaches internally and sometimes name the private sector focus differently like ‘IFC’ for the World Bank as a group. MFI’s have large syndication programs to other type of funders like pension funds, commercial banks, etc. MFI’s can act alone, i.e. provide for the full funding solutions offering blended funding, equity, subordinated debt and senior debt, and are able to perform the ‘duty of care’ (the banking and insurance sectors have been experiencing an ever increasing requirement regarding duty of care for products and services since 1990. This care includes obligations to investigate risks, inform about risks – sufficiently - and warn for them, both in relation to products and services provided (including ‘advisory’)), associated with selling down financial products and providing associated services. Because of the obligation to catalyse other funding and be additional to the market it is key for MFI’s (and DFI’s) to operate within the CAPM-type of market-setting.

### **Bilateral Development Institutions**

Bilateral development institutions function like commercial banks but with a specific emerging market mandate. Since most countries have a bilateral development bank they tend to cooperate, hence, operate in so-called 'club deals'. Different from MFI's the bilateral institutions are not picking up the full financing but reduce risks by taking up to 25 or 30 % of the total project cost or facility. From a risk perspective they therefore need 2 other banks to offer the full financing. Working in club deals is probably quicker but has the disadvantage that transparency is less compared to a market-syndicated transaction.

## **5.6 Commercial Banks with the Use of Export Insurance**

HYPOSO is about promotion of European hydropower solutions with 5 countries in specific for piloting. These 5 countries can be classified as emerging markets. Most hydropower industry players 'export' their equipment and have developed methods of finance their exports. Governments promote export of goods and services and also create finance methods. These methods can be public-to-public sector (like China often does) or public (support)-to-private sector.

### **International Commercial Banks**

In order to create a level playing field in the support of exports it has been internationally agreed to what extent 'Official Development Aid' (ODA) or 'tied aid' can be used in terms and conditions of export finance or export guarantees. How this is arranged in detail can be found at publications by the OECD (2013). The use of ODA is bound by a stringent set of reporting measures. The point made here is that export finance (or guarantees) based on ODA on paper provide for economic preferred solutions, they make exports more attractive. An industry player that exports to a purchaser that resides in an eligible country to receive tied aid might ask its commercial banking relation at home to find out the best export finance possibility and / or guarantee. Mind, in these state-support programs some remaining risks are to be carried by commercial banks such as for example 5 % of the loan 'uncovered' (i.e. the loan is for 95 % covered through the ECA).

The ECA-coverage one might be looking for can be limited to (certain) political risks (expropriation, convertibility of currency and transferability risks) or may include commercial risks as well i.e. 'comprehensive cover'. ECA's are involved if commercial banks that are liaised with the industry player as 'house-bank' or relationship bank would like to support a project or developer in its exports or project development. In case of eligibility of tied aid this finance route is more beneficial than others, although compared to solutions within the CAPM-framework.

### **National Commercial Banks**

National banks do not play a large role in electricity generation projects. Most finance is coming from abroad in hard currency (USD and/or EUR) at terms and conditions (15 to 18 years debt tenors for example) that cannot be considered by local banks.

Without 'concessional funding' to local commercial banks the pricing of a loan will compensate fully for inflation, so nominal levels often are 25 to 30 % per annum. Tenors are limited to 3 to 5 years. With concessional funding from DFIs national banks can be involved in renewable energy and energy efficiency projects and companies. The Sunref program (Sunref, 2020) by AFD from France is very successful in providing such 'green lines' and technical capacity to local commercial banks that on-lend to RE in their countries.

National banks are perceived to play a much bigger role in the future since it is much better for RE to be financed in local currency than in hard currency for 25 years. Also the Covid-19 crisis showed how easily and quickly more than USD 50 billion was pulled out of Africa for example just in the first week of the crisis. The spreads on developing country bonds have been rising sharply in the same period to 400-500 BPS (Basis points (BPS) refers to a common unit of measure for interest rates and other %ages in finance. One basis point is equal to 1/100th of 1 %, or 0.01 %, or 0.0001, and is used to denote the %age change in a financial instrument), while the value of

currencies against the dollar has dropped significantly since the beginning of this year (Chen, 2020). Hence the developing countries would need more local currency to offset USD-obligations and borrowing more will (and has already) become substantially more expensive.

## 5.7 Bond Markets

According to the IMF the African bond markets have been steadily growing in recent years in specific in East Africa (Business Daily, 2020), but nonetheless remain undeveloped. African countries would benefit from greater access to financing and deeper financial markets. Local currency funding is key for future finance of electricity access and bond markets are the step to more local currency issues. At this stage it is, however, not perceived a good funding source for SHP although portfolios of SHP might be a good candidate for securitisation for example.

## 5.8 Pension Funds

Pension Funds have long term liabilities which they ideally match with long term income streams, also from an investment point of view. Hydropower, also SHP, provides such income streams. Direct lending by pension funds to hydropower is not always a possibility but indirectly through for example funds is not uncommon. For example, relatively recent (in 2015), an asset manager by the name of 'Aquila Capital' launched a fund in Europe with dedication to investment in 33 SHP's specifically targeting pension funds ("the first such fund for institutional investors"). The fund aims to achieve returns on its portfolio of 7 to 9 % and it has a lifetime of 20 years (Chestney, 2015). The fund addresses the shortcomings of some pension funds and other institutional investors to build up internal capacities for these infrastructure investments. For emerging markets such capacity would be a bigger obstacle and the more reason for similar type of funds with a focus on SHP in emerging markets.

## 5.9 Other Funding Possibilities

It has not gone unnoticed to many that the CAPM restrictions and imperfect financial markets are present in many sectors but possibilities to work around them are plenty:

### 5.9.1 Development Institutions

Firstly, many development institutions are not 'banks' and as such follow regulations but maybe different from banks. Instead they are named 'International Finance Corporation', 'Deutsche Investitions- und Entwicklungsgesellschaft', etc. Secondly, some institutions themselves are named 'fund' ('Swedfund', 'Norfund', etc.) and most institutions do use fund-structures to set up new and associated activities that need to adhere to fund-goals but these goals can deviate from CAPM requirements. Because of this the funds do meet a ready market but only for one specific risk-mitigation, a focus-element (gender-equality for example) or product (working capital for Solar Home System companies for example) because the establishment of the fund could otherwise not be justified (often set-up with public sector money through development banks, ministries, etc.).

### 5.9.2 Impact Funds

Impact funds emerged in the last 15 years and are addressing the funding of market assets that hardly had access to funding at all and use the CAPM scheme intelligently, i.e. they conform to some extent to its pricing conditions to stay part of the development banking community but also deviate enough from the scheme to make the impact they're aiming at. Although impact investors seems to work proprietary in the energy space they cooperate among each other for both, scaling purposes and cost reduction (due diligence - DD).

### 5.9.3 Crowdfunding

International distributed crowdfunding does not need to follow the CAPM pricing scheme since alternative finance lenders do not have cost of raising capital and are not bound by the Basel Accords.

Crowdfunding nowadays is (still) a proprietary exercise, each platform predominantly works for its own investor-base with its own due diligence and pricing specifics. Hence, a distributed crowdfunding platform (the HYPOSO proposal is part of this suggestion) – given access to funding opportunities to all eligible platforms in Europe (or the world) – would have the benefit of access to the end-private sector lenders, would increase a standardised risk asset class and could reduce DD cost tremendously.

The UK government has been one of the first donors understanding the power of crowdfunding for Africa. It experimented with an 'Allied Exchange Debt' platform, not issued yet, for syndicated crowdfunding to African projects. It also understands risk related to lending in Africa cannot be fully shifted to lenders in Europe and therefore provides amongst others first loss positions in solar-based projects in Africa with crowdfunding platforms in Europe. Crowdfunding is increasingly perceived to become a mainstream solution for funding: „Innovations such as crowdfunding and aggregation are opening PPA markets to more participants.“ (REN 21, Global Status Report, Renewables 2020).

### 5.9.4 Blockchain

The digital revolution in combination with alternative finance, maybe as a complement to existing funding sources, holds the prospect to completely redefine funding to (smaller) renewable energy projects. Given the current absence of long term private sector funding in SSA, it allows to identify a new source of private long-term finance for infrastructure investments - distributed private finance. It also holds the prospect, if not done rightly, to scare away the private sector. Redefining the financial landscape is based on the following building blocks:

- Blockchain technology enables supply contracts to be made with each end-user. This integration, combined with net-metering and pay-as-you-go models allows to fund projects directly on the basis of a pool of end-users through a block chain contract. In principal there would not be geographical boundaries. For example 10,000 end-users of 3 mini-grids in Benin, Madagascar and Burundi could be bundled this way. No utility risk anymore, no government guarantees, termination payments, partial risk guarantee programmes, etc.
- A blockchain contract is probably the most secure way to avoid corruption, making projects more bankable that way.

Cryptocoin issues are for all investors in the world, but cryptocurrencies are volatile.

### 5.9.5 Community Organisations

In Europe community organisation and funding is popular with respect to renewable energy generation and sometimes more than encouraged in for example tenders organised by municipalities (encouraging to open the opportunity for lending or ownership to the local community).

In specific the works of C40 relate to this area where cities are taken as the starting point for renewable energy generation and energy efficiency measures. The C40 initiative is already a 'community' initiative through which 96 cities are connected that represent no less than 700+ million citizens and one quarter of the global economy. Hydropower solutions are part of the solutions. C40 integrates financial solutions in its initiative (C40 Cities, 2020).

## 5.10 Summary

SHP provides for reliable power, has a strong local economic development impact, is green and resilient. Increasingly complex environmental and social constraints and rising costs (both absolute and relative to other renewables) all are increasing the challenges to further hydropower development but maybe less so for small-scale hydropower generation.

Finance-ability of SHP is difficult because of the size of projects and often developers are involved without sufficient own-capital. If projects are bundled the size can be overcome as an issue. Ownership cannot be easily bundled if one would like to support local entrepreneurship, however, debt finance can be grouped. Hence, a green line to a local bank that funds a portfolio of SHPs provides for a viable funding route. Such bank(s) can be selected in countries that have enabling environments through feed-in schemes where tariffs are known. Lending raised to fund the local bank can come from development finance institutions but equally from a group of cooperating European crowdfunding sites, as is proposed by HYPOSO.

Dedicated funds and impact investors showed that finance of portfolio of SHPs is possible. Some development banks showed that funding of individual SHP is also doable. Notable the development institute from Norway, Norfund, has implemented a focussed action on financing SHPs in Africa. Institutions that are able to package portfolio solutions exist (this is done successfully by for example the development institute IFC, member of the World Bank Group) and scaling to the private sector seems very well possible. It is recognized that preparation is key to further scaling of SHP. HYPOSO adds to this, but also an increasing number of parties focus on the preparation of credit applications and the development steps prior to that as well. The International Hydropower Association for example offers a development facility for SHPs.

## 6 Conclusion

This handbook is the result of joint effort of a group of European experts involved in the EU funded HYPOSO project with the full name “HYdroPOwer SOLutions for developing and emerging countries”. The purpose of the project is to assist sharing the European small hydro know-how in these countries in order to achieve important social, economic and environmental goals, such as reliable supply of electricity to some remote areas, developing core components of locally balanced electrical mini grids, boosting the local economic growth and/or increasing its sustainability by replacing the already available Diesel engine based electricity supply with that based on locally available renewable energy potential and emission-free technology. Some further benefits following from developing small hydropower systems have been outlined in the first two chapters of this handbook.

At the time this text is being written (in 2020), project activities are conducted in 5 target countries: Bolivia, Colombia and Ecuador in Latin America, and Cameroon and Uganda in Africa. All of them are represented in the project consortium by relevant educational and research institutions or national hydropower associations. It is to be borne in mind that hydropower is already not only present in the target countries, but also acts as a significant or even leading national supplier of electricity (Bolivia – 26.9 %; Colombia - 77.6 %; Ecuador - 76.3 %; Cameroon - 73 %; Uganda – 91 %;) (Hydropower & Dams, 2020). On the other hand the total generation is often insufficient to meet the needs of emerging economies and the population access to electricity is quite diverse (Bolivia – 90 % with 72 % in rural areas; Colombia – 100 %; Ecuador – nearly 100 %; Cameroon – 60 % with 21 % in rural areas; Uganda – 15 % with 7 % in rural areas) (Liu et al., WSHPD, 2019). Furthermore, the existing access to electricity is often burdened with insufficient capacities and the need to erect long and expensive transmission lines or Diesel engine based local power plants. In all these circumstances the use of locally available small hydropower potential may reveal its full beneficial features.

Small hydropower installations are not just miniaturized copies of the large ones as keeping the specific investment and O&M cost at acceptable level requires often simple, but ingenious and well-proven technology. The top priorities are often shifted from high maximum efficiency to high flexibility and reliability - features essential in case of self-balancing mini grids and allowing to decrease the O&M costs by remote control. Lowering the unwanted environmental impact is eased due to the project scale and possible use of some techniques hardly applicable in case of large hydro.

The European industry has a long tradition in developing technologies dedicated exclusively to small hydro applications in addition to those typical for the large hydro sector. It is probably enough to mention the crossflow and Turgo turbines, both developed over a century ago. Development of small hydro technology accelerated in the end of the 1970s, mainly as a part of global reaction to the world oil crisis. The trend was especially visible in the low head applications as Kaplan and semi-Kaplan units were introduced in various configurations into the production programmes of even the largest turbine manufacturers. The next stimulus came at the turn of the 1980s and 1990s – this time as a part of a general trend to increase the contribution of renewables to the energy mix while keeping care of local environmental impact. Introducing the Archimedes screw based units has appeared a major business success, but a lot of research effort has been put into development of some other fish-friendly designs, including VLH and hydrokinetic units. Meeting the ever rising environmental requirements, including preserving biological continuity of water courses and sediment transportation capabilities have stimulated recently a lot of relevant progress in the design of not only hydraulic units, but also civil engineering works and various auxiliary arrangements. At the current stage of development the European SHP industry has all technical solutions needed to harness sustainably hydropower potentials worldwide. Even for the so called hidden hydro, many concepts exist nowadays. An incomprehensive overview of the available technology has been given in chapter 3 of this publication.

It should be emphasized that a major portion of the recent progress would have never taken place if not the consequent, multiyear research & development policy of European governments and European Commission. With this effort done, the time has come to share even more intensely the available results with partners in Africa

and Latin America for the sake of joint benefit of technology suppliers, national SHP developers, welfare of local communities and sustainable economic growth of the target countries. It is a strong belief of the authors that linking technology transfer with capacity building activities and reliable, long lasting cooperation with European partners will form a good opportunity for small hydropower industry development in the target countries and spreading the resulting expertise in the neighbouring regions.

For this purpose, the methodology adopted within the HYPOSO project assumes bringing together relevant actors from the EU hydropower sector with stakeholders in the selected countries as well as education of new hydropower experts through capacity building activities. The core component of the approach are GIS based studies of small hydropower potential as well as local administrative and economic constraints, and preparing prefeasibility studies for erecting small hydro installations with the use of European technology. Local stakeholders are expected to launch the projects as pilot ones. Local stakeholders as well as active and potential SHP developers and investors are also among key addressees of this book, and especially chapters 4 and 5 in which the most important steps during the SHP development process as well as available international financing schemes have been described, respectively. The authors expect this publication to appear helpful in their activities.

Except the general guidelines on SHP plant development schedule, as discussed in chapter 4, at no stage of their work did the authors endeavor this publication to compete with classic engineering textbooks on developing hydropower installations and design, construction or exploitation of any of their components. Instead, the concept of this publication was to overview the small hydropower related know-how as offered by the European industry as well as numerous design and consulting offices and institutions. Special attention was paid to recent advances which may be the reason of some imbalance in discussing various SHP related technologies. On the other hand, such technologies as digital control of hydropower plants, including diagnostic systems and optimization algorithms, may have received less attention than deserved due to especially swift progress taking place over the recent decades.

As the book is addressed to a very wide circle of readers, some of them without an engineering background, the technical information on hydraulic units and their characteristics has been preceded by explaining some fundamental concepts and allowing thus to understand properly the next sections. By following this approach the authors hope to contribute also to rising the interest in hydropower technologies among the readers not directly related to the sector. Readers who want to find out more or who have questions are welcome to get in contact with the HYPOSO project team. Critical remarks helpful in preparing possible updates of this publication are also welcome.

Further information on the HYPOSO project can be found at the [www.hyposo.eu](http://www.hyposo.eu) website.

HYPOSO Team  
Munich, December 2020



## List of references

- ACRA (2020): Energy program - second phase. (Online) Available: [http://www.acra.it/index.php?option=com\\_content&view=article&id=1020&Itemid=1478&lang=en](http://www.acra.it/index.php?option=com_content&view=article&id=1020&Itemid=1478&lang=en) (29.11.2020).
- Adamkowski, A., Kwapisz, L., Lewandowski, M. (2019): Stress state in steel hydropower pipelines - selected problems, HYDROFORUM 2019 Polish Hydropower Conference, Polanczyk/Solina, October 2019. (Online) Available: [https://drive.google.com/file/d/1kyCF-rpd\\_B\\_gopU9P1kK1LWJsn4YXz8U/view](https://drive.google.com/file/d/1kyCF-rpd_B_gopU9P1kK1LWJsn4YXz8U/view) (29.10.2020)
- Albayrak, I., et al. (2017): An experimental investigation on louvres and angled bar racks. *Journal of Hydraulic Research*. 2017.
- American History (2020): The Public Utility Regulatory Policies Act. (Online) Available: <https://americanhistory.si.edu/powering/past/history4.htm> (22.10.2020).
- Amiblu (2020): Amiblu GRP pipe projects around the world. (Online) Available: <https://www.amiblu.com/technologies/> (29.10.2020).
- Arndt, R.E.A. (1981): Cavitation in fluid machinery and hydraulic structures. *Annual Review of Fluid Mechanics*, 1981, Vol.13, pp.273-328.
- AURES II project (2020a): D5.1 Report on design elements affecting financing. (Online) Available: <http://aures2project.eu/deliverables/> (22.10.2020).
- AURES II project (2020b): AURES II. (Online) Available: <http://aures2project.eu/> (22.10.2020).
- AURES project (2017): AURES. (Online) Available: <https://auresproject.eu/> (22.10.2020).
- Bansal, P., Marshall, N. (2010): Feasibility of hydraulic power recovery from waste energy in bio-gas scrubbing processes, *Applied Energy* 87 (2010) 1048–1053.
- Baselt, I., Malcherek, A., and Maerker, C. (2013): Steffturbine. A micro hydro turbine based on conveyor belt technology. *AFRICA 2013- Water Storage and Hydropower Development for Africa, Int. Journal of Hydropower & Dams Conf.*, Addis Ababa.
- Bau, F., et al. (2008): Suivis par radiopistage de la dévalaison de l'anguille argentée sur le Gave de Pau au niveau des ouvrages hydroélectriques d'Artix, Biron, Castetarbe, Baigts et Puyoo (2007-2008). s.l.: Rapport GHAAPE RA.08.06, 2008.
- Beck, C., et al. (2019): Hydraulic performance of fish guidance structures with curved bars: Part 1: Head loss assessment. *Journal of Hydraulic Research*, <https://doi.org/10.1080/00221686.2019.1671515> (22.10.2020).
- Beck, C., et al. (2019): Hydraulic performance of fish guidance structures with curved bars: Part 2: Flow fields. *Journal of Hydraulic Research*, <https://doi.org/10.1080/00221686.2019.1671516> (22.10.2020).
- Bellmann, R., Sebestyen, A., Wührer, W. (1999): Rebuilding storage pumps for Geesthacht. *Upgrading and Refurbishing of Hydro Power Plants*, Berlin, May 1999.
- Berg, R. (1986): Fish passage through Kaplan turbines at a power plant on the river Neckar and subsequent Eel injuries. *Vie milieu*. 1986, 36 (4), 307-310.
- Biner B., Hasmatuchi V., Violante D., Richard R., Chevailler S., Andolfatto L., Avellan F. and Münch C. (2016): "Engineering & Performance of DuoTurbo: Microturbine with Counter-Rotating Runners", *IOP Conference Series: Earth and Environmental Science*, Volume 49, Sustainable Hydropower.
- Boes, R.M. and Albayrak, I. (2017): Fish guidance structures: new headloss formula and fish guidance efficiency. s.l. : *Proceeding of the 37th IAHR World Congress*, Kuala Lumpur, Malaysia, 2017.
- Boes, R.M. et Albayrak, I. 2017. Fish guidance structures: new headloss formula and fish guidance efficiency. s.l. : *Proceeding of the 37th IAHR World Congress*, Kuala Lumpur, Malaysia, 2017.
- Bousquet, C., Samora, I., Manso, P., Rossi, L., Heller, Ph., and Schleiss, A.J. (2017): Assessment of hydropower potential in wastewater systems and application to Switzerland, *Renewable Energy* 113 (2017) 64e73.
- Brujij, MCM, et al. (2003): Management of silver. s.l.: *EU-Report Contract Q5RS-2000-31141*, 2003.

- Bullani A., Denis, V. (2019): "Diagonal (Deriaz) turbine: from the systematization development to the first project implementations", conference proceedings, Hydro 2019, Porto, Portugal, October 2019.
- Burger Wasserkraftanlagen GmbH (2020): Getriebe und Lager. (Online) Available: <https://www.wasserkraft.biz/produkte/getriebe-lager.php> (29.10.2020).
- Business Daily (2020): Kenya raises \$2bn in fresh Eurobond issue. (Online) Available: <https://www.businessdailyafrica.com/markets/capital/Kenya-says-fresh--2bn-Eurobond-oversubscribed-seven-times/4259442-4315350-format-xhtml-e2n1jaz/index.html> (22.10.2020).
- C40 Cities (2020): The Power of C40 Cities. (Online) Available: <https://www.c40.org/cities> (22.10.2020).
- Chen, J. (2019): International Capital Asset Pricing Model (CAPM). (Online) Available: <https://www.investopedia.com/terms/i/international-capm.asp> (22.10.2020).
- Chen J. (2020): Basis Points (BPS). (Online) Available: <https://www.investopedia.com/terms/b/basispoint.asp> (22.10.2020).
- Chevalier, S., Culshaw, S.T., and Fauquez, J.P. (1996), The Hydroplus Fusegate system – four years on , in : « The reservoir as an asset », A conference organised by the British Dam Society, Thomas Telford Publishing, London, 1996.
- Chong, J., Jin Y., Philips, G.M. (2013): The Entrepreneur's Cost of Capital: Incorporating Downside Risk in the Buildup Method. (Online) Available: <http://www.macrorisk.com/wp-content/uploads/2013/04/MRA-WP-2013-e.pdf> (22.10.2020).
- Choulot, A., Denis, V., et al. (2010): Energy recovery in existing infrastructures with small hydropower plants. Multipurpose Schemes – Overview and examples, ESHA 2010. (Online) Available: [http://www.infrawatt.ch/sites/default/files/2010\\_06\\_07\\_Mhylab%20&%20ESHA\\_Energy%20recovery%20in%20existing%20infrastructures%20with%20small%20hydropower%20plants\\_0.pdf](http://www.infrawatt.ch/sites/default/files/2010_06_07_Mhylab%20&%20ESHA_Energy%20recovery%20in%20existing%20infrastructures%20with%20small%20hydropower%20plants_0.pdf) (11.11.2020).
- Choulot, A., Denis, V., and Punys, P. (2012): Integration of small hydro turbines into existing water infrastructures, [in:] H. Samadi-Boroujeni (Ed.): "Hydropower - Practice and Application", InTech 2012, pp.239-276.
- Chestney, N. (2015): UPDATE 1-Aquila Capital launches European hydropower fund. (Online) Available: <https://www.reuters.com/article/fund-renewables/update-1-aquila-capital-launches-european-hydropower-fund-idUSL5N0XY40Z20150507> (22.10.2020).
- CINK Hydro – Energy (2020): 2-cell Crossflow Turbine. (Online) Available: <https://www.cink-hydro-energy.com/en/2-cell-crossflow-turbine/> (21.10.2020).
- Cottin C., Denis, V. "Developments of Diagonal turbines for flexible medium head small hydro power plants", Conference proceedings, Hydrovision 2017, Denver, USA, June 2017.
- Courret, D. and Larinier, M. (2008): Guide pour la conception de prises d'eau "ichtyocompatibles" pour les petites centrales hydroélectriques. 2008.
- Cowx, I. G., et al. (2020): D1.4 Cumulative Impact Assessment. (Online) Available: <https://www.fithydro.eu/deliverables-tech/> (22.10.2020).
- Cui, X., Binder, A., Schlemmer, E. (2007): Straight-Flow Permanent Magnet Synchronous Generator Design for Small Hydro Power Plants, International Conference on Clean Electrical Power, 2007, DOI: 10.1109/ICCEP.2007.384231.
- Czerwinski, F., Canas, J.-J.R., Marin, P. (2012): SAM turbine: a low head alternative for small hydro projects, Hydroenergia 2012, Wroclaw (Poland) May 24th-25th 2012, Paper 4B01.
- Daniel, R., Paulus, T. (2019): Lock Gates and Other Closures in Hydraulic Projects, Butterworth/Heinemann, 2019, 993 p., (Online) Available: <https://doi.org/10.1016/C2015-0-05399-0> (21.10.2020).
- Denis, V. (2019): "Wastewater turbinage before and after treatment: the example of Amman City – Hashemite Kingdom of Jordan", Conference proceedings, Hydro 2019, Porto, October 2019.

- Denis, V., Cottin, C., Choulot, A. (2016): Design of small Pelton, Kaplan and diagonal turbines, from laboratory tests until manufacturing drawings, or an innovative development to guarantee a high long-term production. Hydrovision 2016, Minneapolis (Minnesota, US), 25-29 July 2016.
- Dewitte, M. (2018): D2.1 A List of solutions, models, tools and devices, their application range on a regional and overall level, the identified knowledge gaps and the recommendations to fill these, <https://www.fithydro.eu/deliverables-tech/> (22.10.2020).
- Dewitte, M. and David, L. (2019): D2.2 Working basis of solutions, models, tools and devices and identification of their application range on a regional an overall level to attain self-sustained fish populations, <https://www.fithydro.eu/deliverables-tech/> (22.10.2020).
- Ebel, G. (2013): *Fischschutz und Fischabstieg an Wasserkraftanlagen - Handbuch Rechen- und Bypasssysteme. s.l. : Ingenieurbiologische Grundlagen, Modellierung und Prognose, Bemessung und Gestaltung. Mitteilungen aus dem Büro für Gewässerökologie und Fischereibiologie Dr Ebel, Band4, 483 S. Halle (Saale). ISBN: 978-3-00-039686-1., 2013.*
- Eisenbeiss (2016): Hydropower - Fit and Forget. (Online) Available: <https://www.eisenbeiss.com/industries/energy-technology/hydropower/> (21.10.2020).
- Energies de la Mer (2019): Fin du projet d'hydroliennes fluviales au barrage de Génissiat – partie 1. (Online) Available: <https://www.energiesdelamer.eu/2019/07/08/fin-hydroliennes-fluviales-barrage-de-genissiat/> (04.11.2020).
- EPRI (1986): Assessment of downstream migrant fish protection technology of hydroelectric application. Boston, Massachusetts : Stone and Webster Eng. Corp., 1986. p. 420.
- EREF (2020): Examples of Mini-Grid Operators. Own table.
- ESHA (2004): Guide on How to Develop a Small Hydropower Plant. Brussels, 2004.
- Flygt (2020): Flygt hydro turbines. (Online) Available: <https://pdf.directindustry.com/pdf/xylem-france/flygt-hydro-turbines/157420-912786.html> (29.10.2020).
- Fontanella, S., Fecarotta, O., Molino, B., Cozzolino, L. and Della Morte, R. (2020): A performance prediction model for Pumps as Turbines (PATs), *Water* 2020, 12, 1175; doi:10.3390/w12041175.
- France Hydro Electricité (2020): L'hydroélectricité au défi de la flexibilité. Modèles économiques. (Online) Available: <https://www.france-hydro-electricite.fr/wp-content/uploads/2020/11/FHE-Flex-dossier-presse-nov-20-2020.pdf> (30.11.2020).
- Franzke, A. (1970): Benefits of energy recovery turbines. *Chemical Engineering*, February 23, 1970.
- Gatte, M.T. and Kadhim, R.A. (2012): Hydropower [in:]: A.A.Ahmed (ed.) "Energy Conservation", *InTech*, 2012, pp.95-124, <http://dx.doi.org/10.5772/52269> (22.10.2020).
- Gale J., Höfler E., Bergant A. (2010): Compact vertical axial turbine „Saxo“, 16th International Seminar on Hydropower Plants – TU Wien 2010.
- Geiger, F., Sepp, A. et Rutschmann, P. (2016): *Korrespondenz Wasser Wirtschaft. s.l.: Vol. 9, Nr. 10, S. 627-632, 2016.*
- Giesecke, J., Mosonyi, E. (1998): *Wasserkraftanlagen: Planung, Bau und Betrieb. Zweite Auflage, Springer 1998, 730 S.*
- Gilkes (2019): 100 Years of the Turgo Impulse Turbine. (Online) Available: <https://www.gilkes.com/media/1809/100-yrs-of-the-turgo-impulse-rev-4.pdf> (21.10.2020).
- Gosset, C. and Travade, F. (1999): *Etude de dispositifs d'aide à la migration de dévalaison des salmonidae: barrières comportementales. 1999.*
- Harper, P. (2015): Public-private partnerships and the financial cost to governments: Case study on the power sector in Uganda. (Online) Available: [https://jubileedebt.org.uk/wp-content/uploads/2015/08/Uganda-case-study\\_08.15.pdf](https://jubileedebt.org.uk/wp-content/uploads/2015/08/Uganda-case-study_08.15.pdf) (23.10.2020).

- Hartvigsen Hydro (2020): Pelton Wheel. (Online) Available: [https://h-hydro.com/New\\_Site/pelton-wheel/](https://h-hydro.com/New_Site/pelton-wheel/) (21.10.2020).
- Hoffmann M. (ed.) (1992): Small hydropower plants. Handbook. 2nd Edition. Nabba Sp. Z O.O., Warsaw 1992 (in Polish).
- Huang, B., Pu, K., Wu, P., Wu, D., and Leng, J. (2020): Design, Selection and Application of Energy Recovery Device in Seawater Desalination: A Review. *Energies* 2020, 13, 4150; doi:10.3390/en13164150.
- Hutchinson (2020): HPP Belt. (Online) Available: <https://www.hutchinsontransmission.com/products-solutions/products/hpp-belt> (21.10.2020).
- Hydroplus (2020): Classic Fusegate. (Online) Available: [http://www.hydroplus.com/hydroplus/hydroplus.nsf/web/hausse\\_classique.htm&lng=L2](http://www.hydroplus.com/hydroplus/hydroplus.nsf/web/hausse_classique.htm&lng=L2) (28.10.2020).
- HydroQuest (2020): River turbines – HydroQuest River. (Online) Available: <https://www.hydroquest.net/river-current-turbine-range-river-hydrokinetic-turbine/> (05.11.2020).
- IDA (2020): Private Sector Window Papers. (Online) Available: <https://ida.worldbank.org/financing/ida18-private-sector-window/psw-papers> (22.10.2020).
- IEC 60041 (1991): Field acceptance tests to determine the hydraulic performance of hydraulic turbines, storage pumps and pump-turbines.
- IEC 60193 (2018): Hydraulic turbines, storage pumps and pump-turbines – model acceptance tests.
- IEC 61116 (1992): Electromechanical equipment guide for small hydroelectric installations.
- International Journal on Hydropower & Dams (2020): World Atlas & Industry Guide 2020.
- IRENA (2019): Global energy transformation: A roadmap to 2050 (2019 edition), International Renewable Energy Agency, Abu Dhabi. (Online) Available: [https://irena.org/-/media/Files/IRENA/Agency/Publication/2019/Apr/IRENA\\_Global\\_Energy\\_Transformation\\_2019.pdf](https://irena.org/-/media/Files/IRENA/Agency/Publication/2019/Apr/IRENA_Global_Energy_Transformation_2019.pdf) (19.10.2020).
- Kenton, W. (2020): Capital Asset Pricing Model (CAPM). (Online) Available: <https://www.investopedia.com/terms/c/capm.asp> (22.10.2020).
- Keuneke, R. (ed.) (2014): Vorbereitung und Begleitung der Erstellung des Erfahrungsberichts 2014 gemäß § 65 EEG. Vorhaben IId Stromerzeugung aus Wasserkraft. Zwischenbericht. Ingenieurbüro Floecksmühle, 2014, 257 S. (Online) Available: [https://www.erneuerbare-energien.de/EE/Redaktion/DE/Downloads/bmwi\\_de/bericht-eeg-5-wasserkraft.pdf?\\_\\_blob=publicationFile&v=4](https://www.erneuerbare-energien.de/EE/Redaktion/DE/Downloads/bmwi_de/bericht-eeg-5-wasserkraft.pdf?__blob=publicationFile&v=4) (21.10.2020).
- Khan, M.J., Bhuyan, G., Iqbal, M.T., and Quaicoe, J.E. (2009): Hydrokinetic energy conversion systems and assessment of horizontal and vertical axis turbines for river and tidal applications: A technology status review. *Applied Energy* 86 (2009) 1823–1835.
- Khan M.N.I., Iqbal M.T., Hinchey M., Masek V. (2009): Performance of Savonius rotor as a water current turbine. *J Ocean Technol*, 4 (2) (2009), pp. 71-83.
- Kroll, L. (2015): Eel protection Initiative (EPI) Rhineland-palatinate/ RWE Power AG on the Moselle river with special reference to "catch & carry" methods. s.l.: International Conference on Engineering and Ecohydrology for Fish Passage 2015, 2015.
- KSB (2012): Pumps Used as Turbines. (Online) Available: <https://www.ksb.com/blob/52840/e415e5c5191fe2be2aa5a2f83a243a44/pumpen-als-turbinen-en-data.pdf> (21.10.2020).
- Kumar, A., Saini, R.P. (2016): Performance parameters of Savonius type hydrokinetic turbine – A Review. *Renewable and Sustainable Energy Reviews* 64 (2016), pp. 289–310, <http://dx.doi.org/10.1016/j.rser.2016.06.005> (22.10.2020).
- Larinier, M., Travade, F., and Porcher, J. P. (2002): Fishways: biological basis, design criteria and monitoring. 2002, p. 208.

- Lashofer, A., Hawle, W., Kaltenberger, F., and Pelikan, B. (2013): Die Wasserkraftschnecke – Praxis, Prüfstand und Potential. Österreichische Wasser- und Abfallwirtschaft, Oktober 2013, DOI: 10.1007/s00506-013-0106-2.
- Leclerc, M. (2008): The Very Low Head Turbogenerator set concept. Evaluation of 1st year operation. Hidroenergija 2008, Bled (Slovenia) June 12th-13th 2008, Session 5A “SHP Innovation”, 8 p.
- Little, N. (2016): Induction generator for wind power generation. (Online) Available: <https://slideplayer.com/slide/10953057/> (29.10.2020).
- Liu, D., Liu, H., Wang, X., and Kremere, E., eds. (2019): World Small Hydropower Development Report 2019: Case Studies. United Nations Industrial Development Organization; International Center on Small Hydro Power. p. 12. (Online) Available: [https://www.unido.org/sites/default/files/files/2020-05/UNIDO%20Case%20Studies\\_for%20web.pdf](https://www.unido.org/sites/default/files/files/2020-05/UNIDO%20Case%20Studies_for%20web.pdf) (28.10.2020).
- Mala voda (2020): Turbína Turgo. (Online) Available: <http://mve.energetika.cz/primotlaketurbiny/turgo.htm> (21.10.2020).
- Michałowski S., Plutecki J.(1975): Hydropower, Wydawnictwa Naukowo-Techniczne, Warsaw (in Polish).
- MGP (2020): State of the Global Mini-grids Market Report 2020. (Online) Available: <https://www.seforall.org/system/files/2020-06/MGP-2020-SEforALL.pdf> (28.10.2020).
- MIGA (2020): Tina Hydropower Limited. (Online) Available: <https://www.miga.org/project/tina-hydropower-limited> (22.10.2020).
- Münch-Alligné C., Schmid J., Richard S., Gaspoz A., Brunner N., Hasmatuchi V.(2018): “Experimental Assessment of a New Kinetic Turbine Performance for Artificial Channels “, Water 2018, Volume 10, Issue 3, 311.
- OECD (2013): Arrangement on Officially Supported Export Credits. (Online) Available: [http://www.oecd.org/officialdocuments/publicdisplaydocumentpdf/?doclanguage=en&cote=tad/pg\(2013\)1](http://www.oecd.org/officialdocuments/publicdisplaydocumentpdf/?doclanguage=en&cote=tad/pg(2013)1) (22.10.2020).
- Ossberger (2018): OSSBERGER® Crossflow Turbine. (Online) Available: <https://ossberger.de/en/hydropower-technology/ossbergerr-crossflow-turbine/> (21.10.2020).
- Perrig, A. (2007): Hydrodynamics of the free surface flow in Pelton turbine buckets. Thèse NO 3715 (2007), Lausanne, EPFL, 242 p.
- Pfleiderer, C., Petermann, H. (1986): Strömungsmaschinen. Springer-Verlag.
- Pucher, E. (1996): Entwicklung und Einsatzbereich der Banki-Turbine 1916 bis 1996. Wasserwirtschaft, 86 (1996) 12, S. 640-644.
- Punys, P., Dumbrasukas, A., Kasiulis, E., Vyčienė, G., Šilinis, L. (2015): Flow regime changes: from impounding a temperate lowland river to small hydropower operations. Energies 2015, 8, 7478-7501; doi:10.3390/en8077478.
- Raabe, J. (1985): Hydro Power. The design, use, and function of hydromechanical, hydraulic, and electrical equipment. VDI-Verlag GmbH, Düsseldorf 1985, 684 S.
- Raabe, J. (1989): Hydraulische Maschinen und Anlagen, 2.Auflage, VDI Verlag, Düsseldorf.
- Raynal, S., et al. (2014): Streamwise bars in fish-friendly angled trashracks. s.l. : Journal of Hydraulic Research Vol. 52, No. 3 (2014), pp. 426–431, 2014.
- Rohloff (2020): Planetary Gear System. (Online) Available: <https://www.rohloff.de/en/experience/technology-in-detail/planetary-gear-system> (21.10.2020).
- Rohmer, J., Knittel, D., Sturtzer, G., Flieller, D., and Renaud, J. (2016): Modeling and experimental results of an Archimedes screw turbine. Renewable Energy 94 (2016) 136-146, <http://dx.doi.org/10.1016/j.renene.2016.03.044> (22.10.2020).
- Rutschmann, P., et al. (2011): International Water Power & Dam Construction. 2011.
- Saini, G., Saini, R.P. (2019): A review on technology, configurations, and performance of cross-flow. hydrokinetic turbines. Int. J. Energy Res. 2019; 43:6639–6679, <https://doi.org/10.1002/er.4625> (22.10.2020).

- Schleker, T. (2020): Hydropower Research & Innovation: The European viewpoint. Hydropower Europe Workshop, 12-13 October 2020 (online workshop).
- Sobczyk, T., Węgiel, T., Grahl-Madsen, M., and Styrylski, M. (2010): Integrated turbine with PM generator for small hydropower plants. Technical Transactions. Series Electrical Engineering, 1-E/2010, Issue 17, pp. 99-111. (Online) Available: [https://repozytorium.biblos.pk.edu.pl/redo/resources/33254/file/suwFiles/SobczykT\\_IntegratedTurbine.pdf](https://repozytorium.biblos.pk.edu.pl/redo/resources/33254/file/suwFiles/SobczykT_IntegratedTurbine.pdf) (21.10.2020).
- Stoltz, U. and Geiger, F. (2019): D3.1 Guidelines for mortality modelling. (Online) Available: <https://www.fithydro.eu/deliverables-tech/> (22.10.2020).
- Strom-Boje (2020): Der Mittelrhein. (Online) Available: [http://strom-boje.de/?page\\_id=11](http://strom-boje.de/?page_id=11) (23.10.2020).
- Sulzer, 2020: Hydraulic power recovery turbine. (Online) Available: <https://www.sulzer.com/en/shared/applications/hydraulic-power-recovery-turbine> (21.10.2020).
- Sunref (2020): Towards a greener future. (Online) Available: <https://www.sunref.org/en/> (22.10.2020).
- Tesgera, S. (2018): Assessment of untapped hydropower potential in existing hydraulic infrastructures. A case study of lower Awash basin, Ethiopia. MSc Thesis WSE-HERBD-18-19. UNESCO-IHE Institute for Water Education, Delft.
- TB Hydro (2020): High performance valves installed on all continents. (Online) Available: <https://tbhydro.com.pl/en> (21.10.2020).
- The World Bank (2014): World Bank to Finance New Hydropower Development in Burundi. (Online) Available: <https://www.worldbank.org/en/news/feature/2014/04/22/world-bank-to-finance-new-hydropower-development-in-burundi> (22.10.2020).
- Therrien, J. and Verreault, G. (1998): Évaluation d'un dispositif de dévalaison et des populations d'anguilles en migration dans la rivière Rimouski. 1998.
- Travade, F., Gouyou, G. and De Faveri, N. (1999): Efficacité d'un exutoire de dévalaison et d'une barrière acoustique pour les smolts de saumons atlantiques (*Salmo salar* L.) à l'aménagement hydroélectrique de St Cricq sur le gave d'Ossau. 1999.
- USACE, n.d: Cutaway cross-section of the spillway at Bonneville Dam with tainter gates and flip lip. (Online) Available: [https://en.wikipedia.org/wiki/File:Bonneville\\_Dam\\_spillway\\_cross-section.png](https://en.wikipedia.org/wiki/File:Bonneville_Dam_spillway_cross-section.png) (22.10.2020).
- VDE (2015): Wasserkraftwerk Rheinfelden: eine Erfolgsgeschichte, gekrönt durch einen IEEE-Milestone 2014. (Online) Available: <https://www.vde.com/de/etg/arbeitsgebiete/informationen/wasserkraftwerk-rheinfelden-ieee-milestone2014> (15.10.2020).
- Voith (2018): StreamDiver®. Utilizing New Hydropower Potential. (Online) Available: <http://voith.com/uk-en/hydropower-components/streamdiver.html> (21.10.2020).
- Walcher (2020): Historie der Wasserkraft. (Online) Available: <http://wasserkraft-walcher.de/historie-der-wasserkraft/> (19.10.2020).
- Wessel (ed) (1991): Moderne Energie für eine neue Zeit – Die Drehstromübertragung Lauffen a. N. – Frankfurt a. M. 1891. In: Geschichte der Elektrotechnik. Band 11. vde-Verlag, Berlin 1991, ISBN 978-3-8007-1813-9.
- Wiegand (2020): Federwehr. (Online) Available: <https://www.wiegandslide.com/federwehr-stauwehr.html> (29.10.2020).
- Wolter, C., et al. (2019): D1.3 Fish Population Hazard Index, <https://www.fithydro.eu/deliverables-tech/> (22.10.2020).
- XFLEX HYDRO (2020): Building a resilient, renewable power system with innovative hydropower technology. (Online) Available: <https://xflexhydro.net/news/building-a-resilient-renewable-power-system-with-innovative-hydropower-technology> (22.10.2020).

Zdrallek, M. (2018): Netztechnischer Beitrag von kleinen Wasserkraftwerken zu einer sicheren und kostengünstigen Stromversorgung in Deutschland. (Online) Available: [https://www.wasserkraft-deutschland.de/fileadmin/PDF/Gutachten\\_Netztechnischer\\_Beitrag\\_Kleinwasserkraftwerke.pdf](https://www.wasserkraft-deutschland.de/fileadmin/PDF/Gutachten_Netztechnischer_Beitrag_Kleinwasserkraftwerke.pdf) (29.10.2020).

Zhangh, J., Leontidis, V., Dazin, A., Tounzi, A., Delarue, Ph., et al. (2018): Canal lock variable speed hydropower turbine design and control. IET Renewable Power Generation, 2018, 12 (14), pp.1698-1707. hal-02138305.